

City of Greater Shepparton

**Goulburn Valley
Wayfinding Strategy**

Style Guidelines



01 Introduction

Introduction	04
Background	04
Audience & Signage Interaction	05
Signage Family Types & Purpose	06
Signage Placement Rationale	07
Design Principles	08

02 Design Elements

Colour Palette	10
» Accessibility	11
» Colour Examples	12
Materials Palette	14
Typography	15
Directional Information	16
Iconography	17
Mapping	18
» Town Map	18
» Regional Map	19
Brandmark Usage	20

03 Signage Family

Viewing Heights and Distances	22
Signage Overview	23
Individual Towns	26
Sign Types	29
» Plinth	29
» Directional Fingerboard	31
» Site Identification	32
» Trail Marker	33

04 Installation & Maintenance

Principles for Placement	35
Appropriate usage of sign family	36
Installation Guide	37
Maintenance	37

04 Technical Specifications

Plinth	39
Site Identification	45
Directional Fingerboard	46
Trail Marker	47

01

Introduction

City of Greater Shepparton

Overview

Introduction

Background

Audience & Signage Interaction

Signage Family

Types & Purpose

Signage Placement Rationale

Design Principles

Introduction

Welcome to the Goulburn Valley Wayfinding Signage Style Guide.

The aim of the Goulburn Valley Wayfinding Strategy is to create better connected communities. By providing pedestrians with on-street information, wayfinding signage helps to connect visitors and locals with public transport, retail areas, historical walks and local facilities. Walking time information also assists pedestrians in making better informed choices about the distances they can travel on foot, and encourages more active and sustainable modes of transport.

What is wayfinding signage?

All people wayfind in one way or another, the term wayfinding encompasses the way we navigate and spatially orientate ourselves within spaces and from place to place.

Wayfinding signage is therefore designed specifically to assist in the process of orientation and navigation through the use of map, directional and location information. Due to the specific nature of their role in the public realm, their role should not to be confused with interpretative and other types of signage.

Background

The Goulburn Valley Wayfinding Signage system was developed through a collaborative process involving the City of Greater Shepparton, and the Shires of Strathbogie and Moira. Following internal stakeholder consultation with all Councils, a set of recommendations were developed to inform the design and function of a wayfinding strategy for towns and regional centres. The strategy identified the need for a flexible, cost effective and customisable sign system to meet the objectives of increased foot traffic in and around the municipalities.

Strategy objectives:

- » Develop a visual identity using clear and legible contemporary graphic design principles.
- » Develop a visual grammar for a culturally and linguistically diverse audience.
- » Limit the number of signs through better location and integration.
- » Create contextual and sympathetic design outcomes.
- » This style guide document provides the necessary design and technical information for the City of Greater Shepparton to implement wayfinding signage across the municipality.

Project outcomes:

- » Movement will be an easy, memorable and safe experience
- » Increased permeability through the street network
- » Pedestrian-friendly streets that are safe, comfortable and pleasant
- » Increased walking and improved community well-being
- » A better connected community
- » Increased retail profitability due to more foot traffic and longer stays

Audience & Signage Interaction

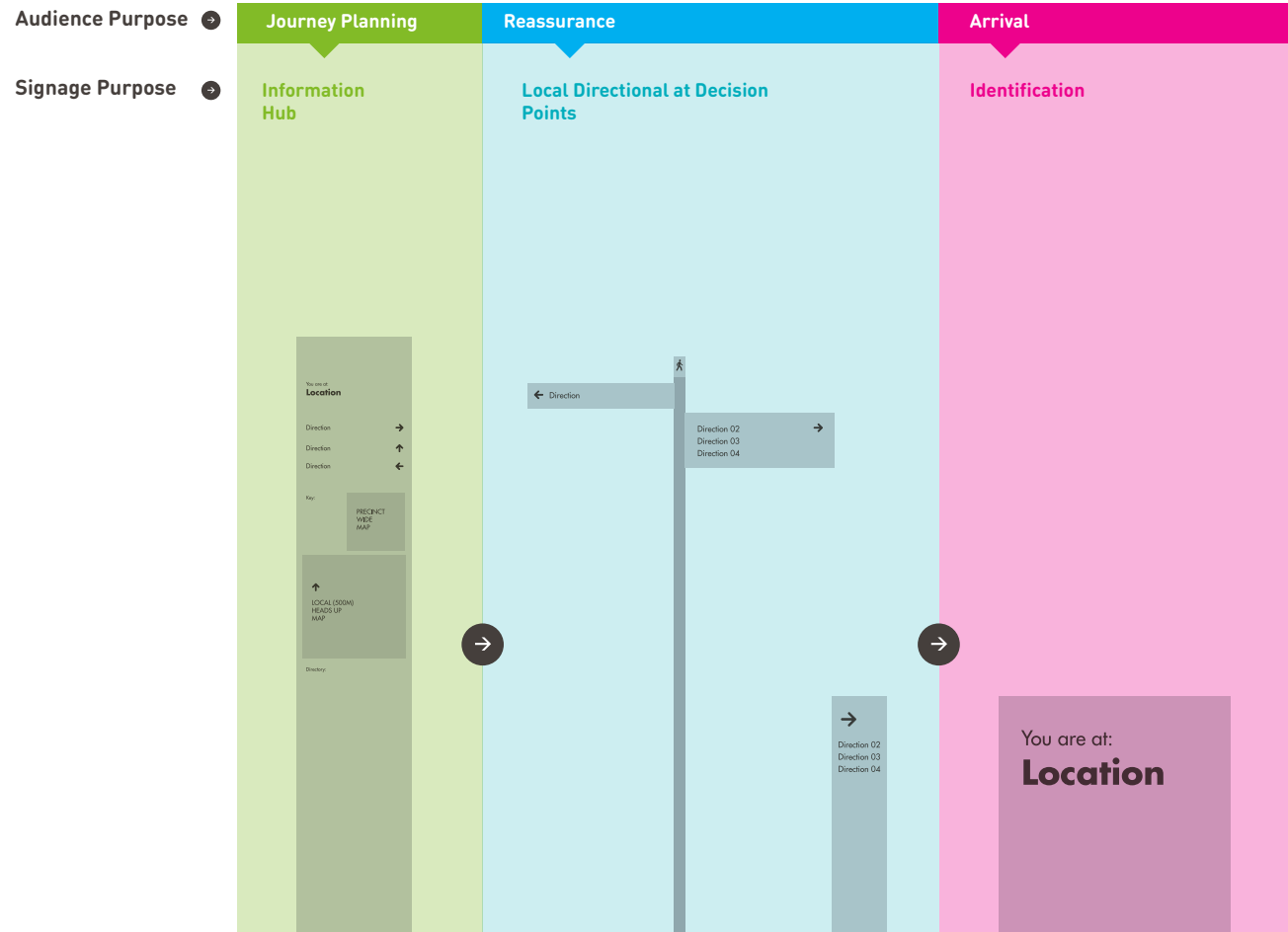

Signage Family Types & Purpose

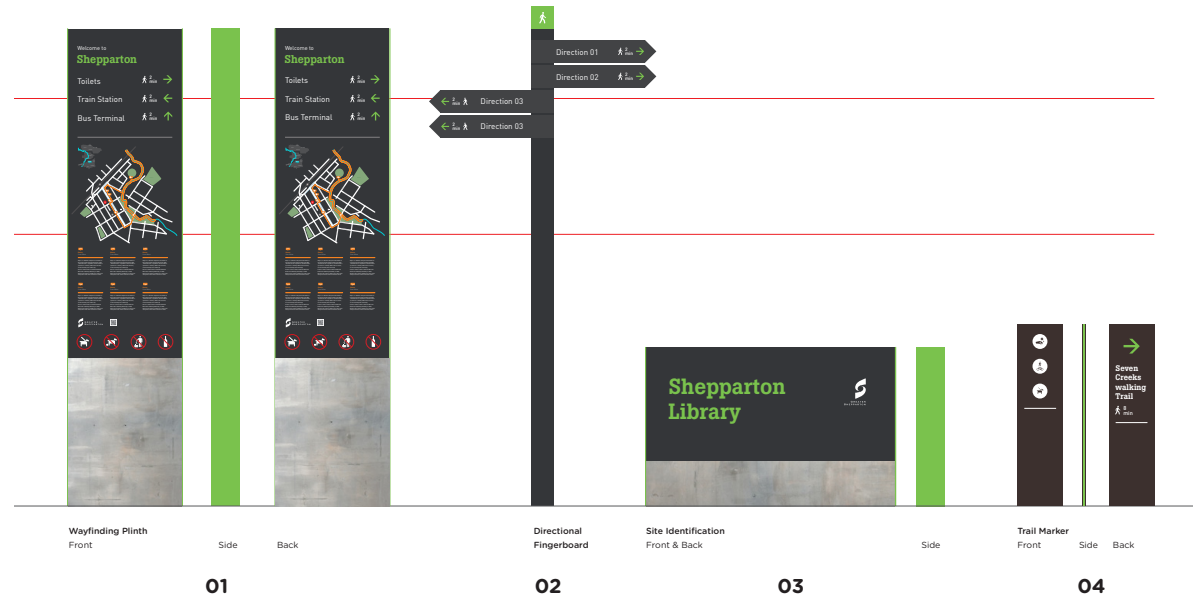

Sign Number & Name	01 Wayfinding Plinth	02 Directional Fingerboard	03 Site Identification	04 Trail Markers
Sign Type	Major information nodes	Local directional	Destination arrival	Macro directional
Purpose	To provide users with key mapped information in two key directions. These signs should direct people for a journey of 500m. Mapped Plinths are appropriate at hub locations where there are surrounding attractions e.g. Transport nodes, Parks with facilities & Town Centres. Mapped Plinths also contain three key directional points at the top.	To provide users with key directional information at nodes where existing infrastructure does not permit co-location.	To provide users with key directional information at nodes where existing infrastructure does not permit co-location.	To provide users with directional information along trails. Can be used as a regulatory bollard and smaller site identification if required.
Example Location	Shepparton Train Station Main Retail Centre, Euroa.	At corner or trail intersection decision points.	At arrival to key facilities e.g. Library, Civic Hall.	Along trails, regulatory for parks or site identification to integrate with Town Walk Maps

Signage Placement Rationale

Sign locations should be determined by assessing circulation routes and decision points within the scope of the town, project or precinct environment.

The project objectives will also impact the number and location of signs. For example, a larger activity centre may look to connect public transport with cycling or car parking with key facilities for pedestrians. Whereas a town may look to promote historical walks for tourists or direct visitors from RV sites to the retail centre of town.

The map opposite illustrates an indicative placement of wayfinding and site identification signage for a town walk. It demonstrates the hierarchy of mapped plinths at key nodal locations (train station, retail centre) with supporting fingerboard and trail markers to create a bread-crum trail along the desired trail network. Site identification signs highlights key facilities along the route.

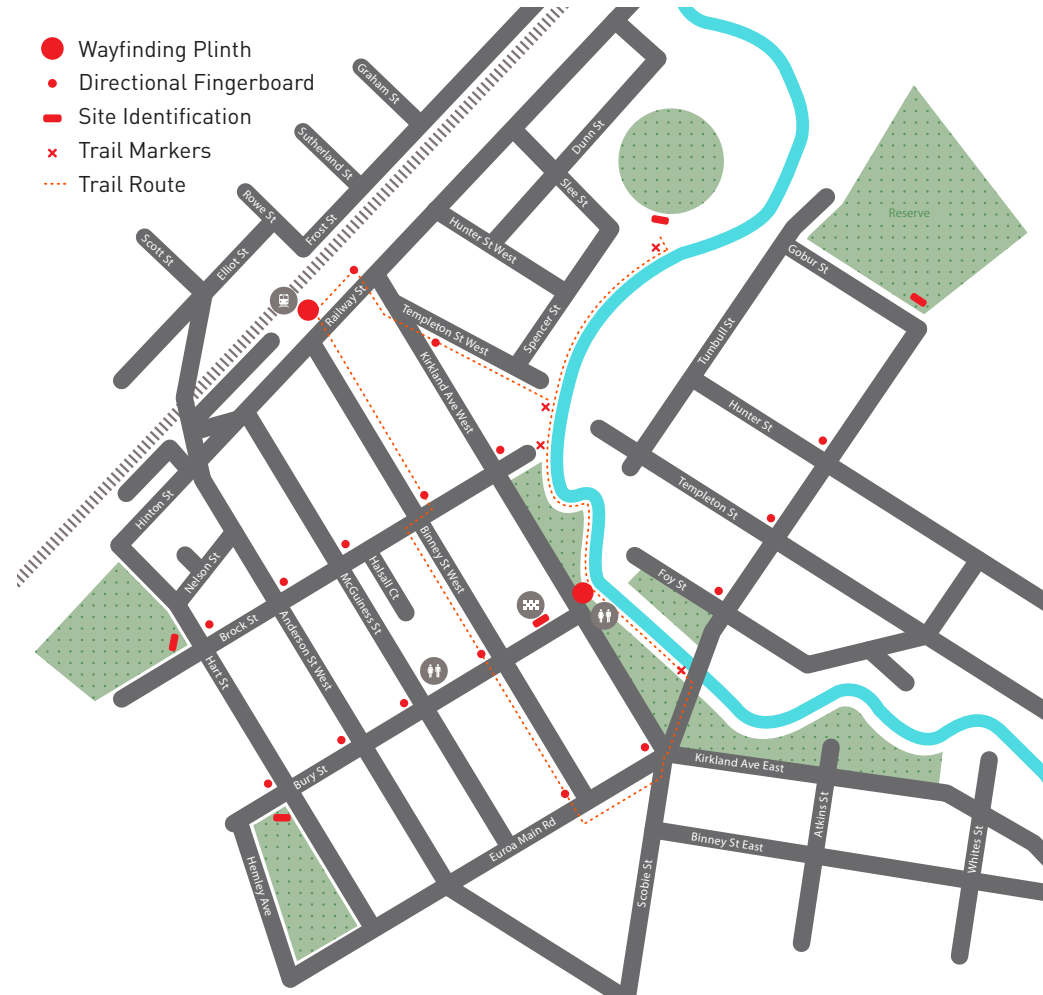

Design Principles

The Goulburn Valley Wayfinding Signage family has been designed as a system to provide for both consistency and customisation.

Consistency:

The form, structure, typography, graphic elements and composition of the signage family remain consistent across all towns and municipalities. This enables economies of scale in design and manufacturing. It means new sign designs are not required each time, and production methods remain the same across the suite. This ensures that design and production costs are reduced.

Consistency also helps in terms of communicating to the public. Visitors travelling from town to town across the region are able to identify the signs as being part of the same suite, thus it helps to tie the region together. It also provides a clear, proud and well-presented voice for the region.

Customisation:

Balancing the need for a consistent suite of signage is also the desire for each town to communicate its own unique character. An important part of the Goulburn Valley Wayfinding Signage system is the capacity for each town to choose a colour and materials palette to suit the unique characteristics of their local region.

As part of the "Design Elements", a choice of 19 colours (see page 05) and 11 materials (see page 09) have been provided. Each town can select a colour and a material which best suits their local character. The signage family examples on pages 18-28 demonstrate examples of these different materials and colours working together.

Each sign is designed and detailed to accommodate this change in colour and material, thereby ensuring both consistency and customisation are achieved within the one system.

02

Design Elements

City of Greater Shepparton

Overview

Colour Palette

- » Accessibility
- » Colour Examples

Materials Palette

Typography

Directional Information

Iconography

Mapping

- » Regional Map
- » Town Map

Brandmark Usage

Colour Palette

An extended colour palette has been developed to allow for customisation across different towns. The colours range from brighter tones of yellows, pinks, greens and blues; through to earthier hues of burnt oranges, tans and olive greens.

These colours are available across all three municipalities, to enable maximum choice for towns.

Pantone 2925C	Pantone 306C	Pantone 319C	Pantone 3265C	Pantone Green C	Pantone 354C	Pantone 7488C	Pantone 583C	Pantone 567 C	Pantone 3985C	Pantone 723C	Pantone 465C	Pantone 129C	Pantone 124C	Pantone 157C	Pantone 138C	Pantone Orange 021C	Pantone 177C	Pantone 2645C
C = 80 M = 25 Y = 05 K = 00	C = 75 M = 00 Y = 05 K = 00	C = 65 M = 00 Y = 21 K = 00	C = 82 M = 00 Y = 42 K = 00	C = 100 M = 00 Y = 65 K = 00	C = 94 M = 00 Y = 100 K = 00	C = 56 M = 00 Y = 93 K = 00	C = 32 M = 13 Y = 100 K = 00	C = 57 M = 22 Y = 91 K = 04	C = 45 M = 33 Y = 100 K = 09	C = 24 M = 63 Y = 100 K = 10	C = 25 M = 40 Y = 74 K = 03	C = 00 M = 10 Y = 80 K = 00	C = 00 M = 30 Y = 100 K = 00	C = 03 M = 43 Y = 76 K = 00	C = 05 M = 55 Y = 97 K = 00	C = 00 M = 83 Y = 100 K = 00	C = 00 M = 63 Y = 32 K = 00	C = 31 M = 43 Y = 00 K = 00

Accessibility

Accessibility and light coloured text on a dark background

As part of the world's best practice signage and wayfinding system, Bristol Legible City, a number of tests were carried out on out-of-doors readability. The tests found that white text on a dark background is more readable at distance, and the use of lower case letters aids the recognition of words. Further to this, the Outdoor Advertising Institute in the US has found reverse messages to be up to 40% more visible.

Another key factor in choosing colours for outdoor signage is to ensure sufficient contrast between the foreground and background colours. Each colour has a Light Reflective Value (LRV) and contrast levels are measured by comparing the foreground and background LRV ratings. 70% is deemed to be an acceptable standard of contrast, making signage more legible for persons with vision impairment.

Generally this means that highlight colours need to be lighter in tone to achieve sufficient contrast with the background. This tends to exclude colours such as reds and maroons, or dark blues and purples. All highlight colours selected for the Goulburn Valley wayfinding colour palette achieve a contrast level of 70% and over.

Contrast Not Acceptable ❌

Contrast Acceptable ✅

These examples show the colours working with typography.

Pantone 2925C

Town Name

Toilets  2 min 

Pantone 3265C

Town Name

Toilets  2 min 

Pantone 7488C

Town Name

Toilets  2 min 

Pantone 306C

Town Name

Toilets  2 min 

Pantone Green C

Town Name

Toilets  2 min 

Pantone 583C

Town Name

Toilets  2 min 

Pantone 319C

Town Name

Toilets  2 min 

Pantone 354C

Town Name

Toilets  2 min 

Pantone 567 C

Town Name

Toilets  2 min 

These examples show the colours working with typography.

Pantone 3985C

Town Name

Toilets  2 min 

Pantone 129C

Town Name

Toilets  2 min 

Pantone Orange 021C

Town Name

Toilets  2 min 

Pantone 723C

Town Name

Toilets  2 min 

Pantone 124C

Town Name

Toilets  2 min 

Pantone 177C

Town Name

Toilets  2 min 

Pantone 465C

Town Name

Toilets  2 min 

Pantone 138C

Town Name

Toilets  2 min 

Pantone 2645C

Town Name

Toilets  2 min 

Materials Palette



Compressed Fibre Cement Sheet

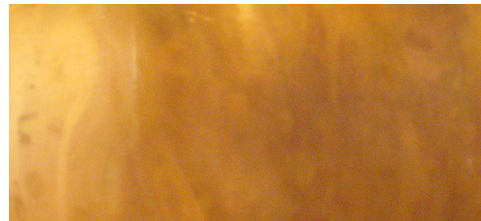

Copper Panel - Larsons Metals Copper



Copper Panel - Aged Patina

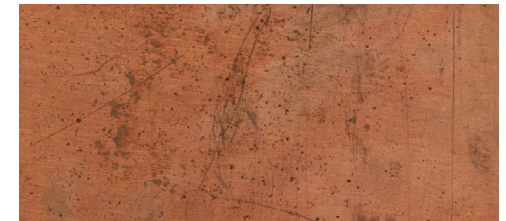

Brass Panel- Larsons Metals Brass



Painted Steel - Dulux WEATHERMAX HBR

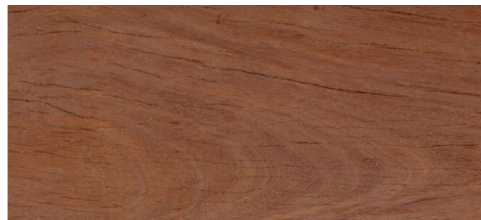

Timber - Red Gum



Timber - Spotted Gum



Timber - Cyprus Pine



Stone - Granite



Stone - Blue Stone

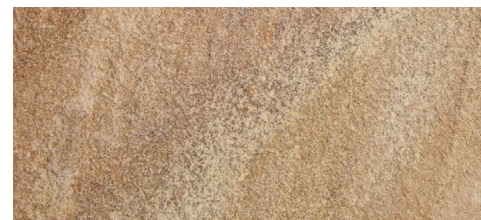

Stone - Sandstone

Typography

Note: Wording on signs should all be in sentence or Title Case (as appropriate) for legibility.

EG:

Town Name

Facilities and attractions

**ABCDEFGHIJKLM
NOPQRSTUVWXYZ
abcdefghijklm
nopqrstuvwxyz
0123456789**

Boton Medium

ABCDEFGHIJKLM
NOPQRSTUVWXYZ
abcdefghijklm
nopqrstuvwxyz
0123456789

Din Regular

Directional Information

Users are never directed to facilities which are behind them. Only forwards, left, right and 45° angles are used. Backwards arrows are open to misinterpretation and become confusing for users.

Arrow types:

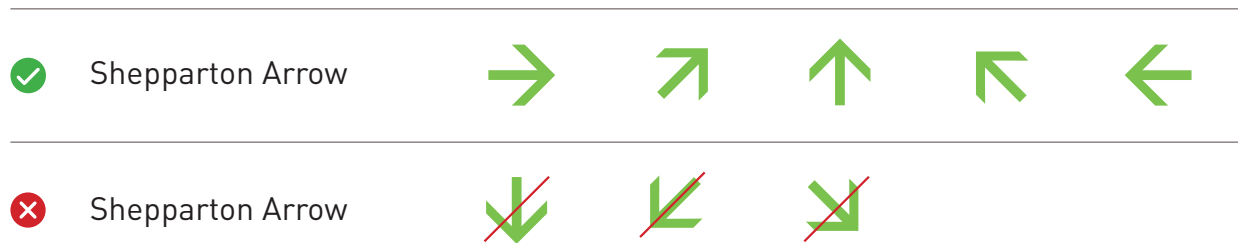

Time vs Distance

Walking time information has been used rather than distances. This is designed to make walking to destinations more achievable, as distances are often misunderstood. This approach ties in with sustainable transport principles. Walking times are based on the following equation:

80 meters distance = 1 minute walking

A walking icon is included next to the walking time to give context.

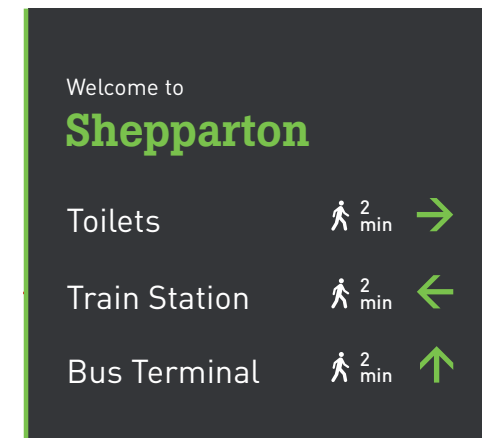

Iconography



Walking



Dogs on Leash



Cycling



Shared Path



Police



Toilets



Picking of Plants Prohibited



Bus



Train



Wheelchair Accessible

Town Map



Regional Map



Mono Brandmark

When implementing the City of Greater Shepparton brandmark into the signage system, it is essential to ensure that it is legible and reproduces consistently across all signs.

In keeping with the simplified colour palette of the signage system, the mono reverse version of the brandmark has been used throughout. This simplified version of the brandmark aids accessibility and ensures the hierarchy of information is maintained.

An optional QR code can be added which takes users directly to a web address on their mobile devices. This could be the council's website, or – to provide more relevance for visitors – it could be a link to an online walking tour of the town.

QR codes can either be printed directly onto the signs or added at a later date as a sticker.

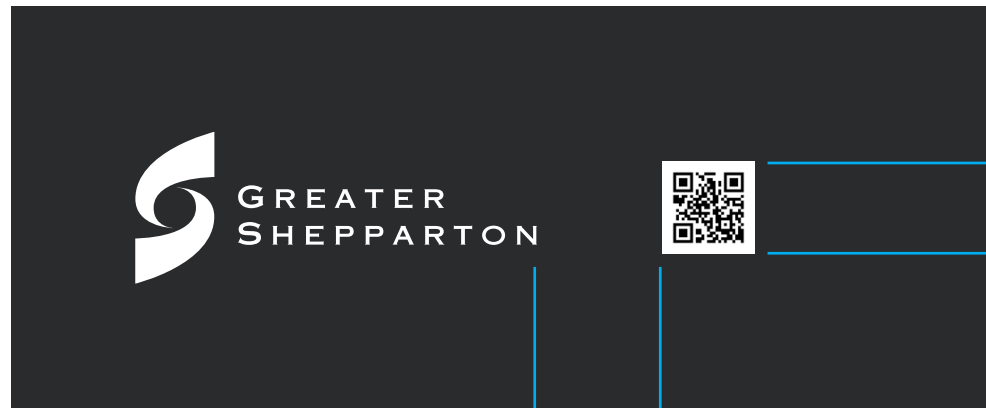

QR Code
Optional
25mm

34mm

03

Signage Family

City of Greater Shepparton

Overview

Viewing Heights and Distances

Signage Overview

Individual Town

Sign Types

- » Plinth
- » Directional Fingerboard
- » Site Identification
- » Trail Marker

Optimum Viewing Heights

All signs have been designed to maximise the optimum viewing zone of 1220mm - 1800mm high.

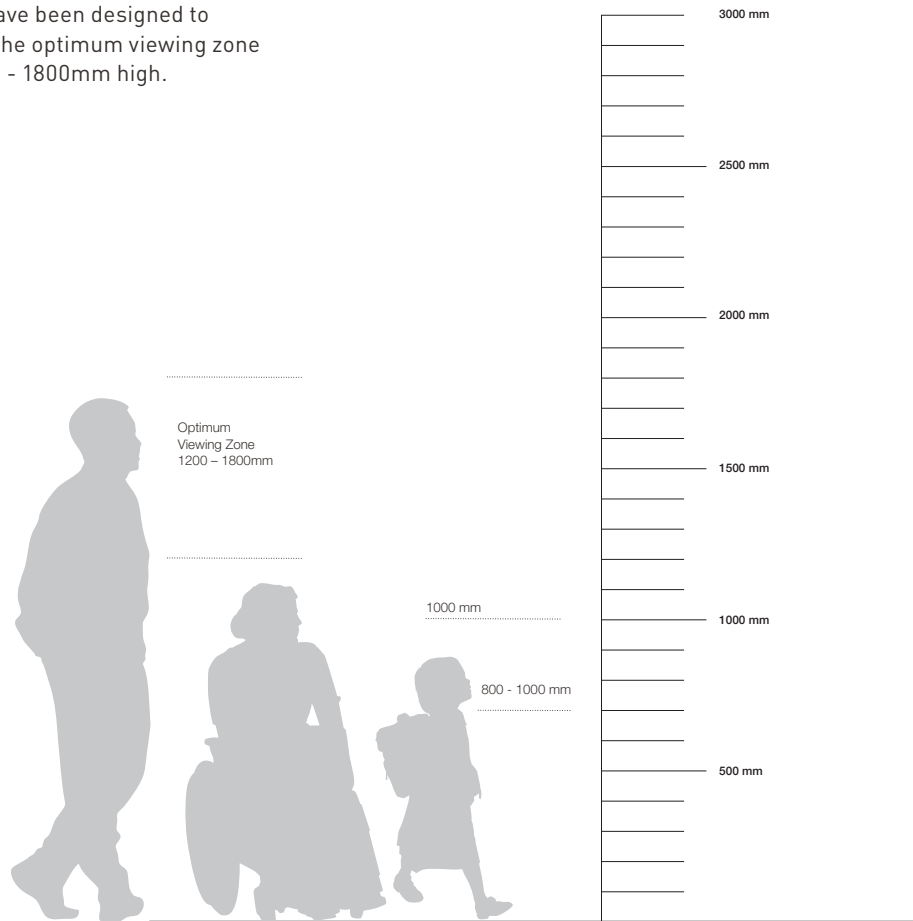

Pedestrian Viewing Distances

Please refer to the table below for a guide to appropriate text height viewing distances as illustrated in signage type break down.

Required Viewing Distance	Minimum Height of Letters
2 meters	6 millimetres
4 meters	12 millimetres
6 meters	20 millimetres
8 meters	25 millimetres
12 meters	40 millimetres
15 meters	50 millimetres
25 meters	80 millimetres
35 meters	100 millimetres
40 meters	130 millimetres
50 meters	150 millimetres

Signage Overview

Customised colour & materials palette for individual towns. Example shown uses Pantone 7488C with cement sheet.

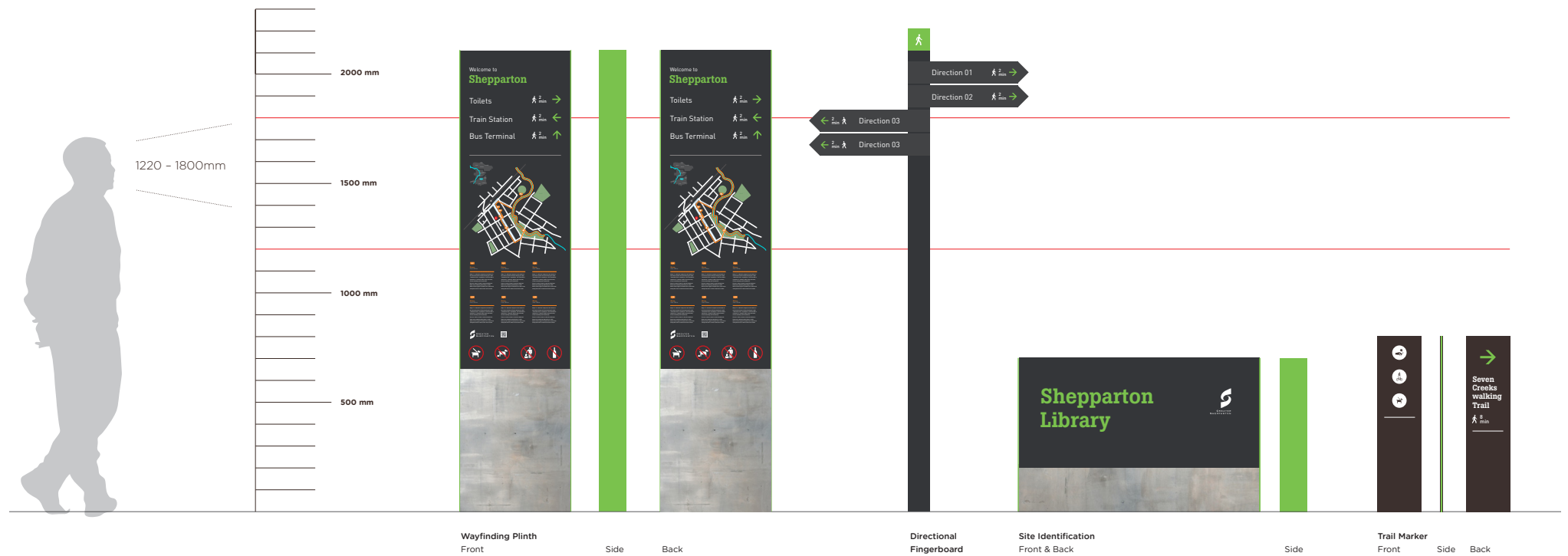

Signage Overview

Customised colour & materials palette for individual towns. Example shown uses Pantone 319C with Spotted Gum timber.

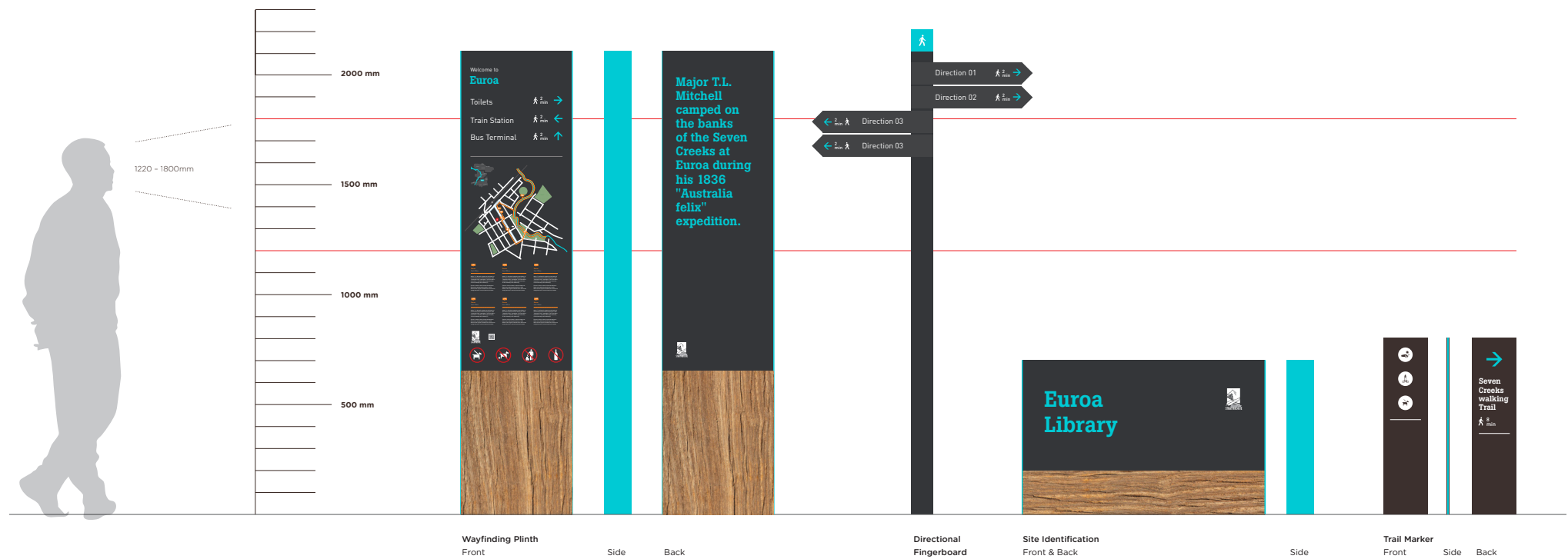

Example shows Euroa from Strathbogie, but can be customised across any town/municipality.

Signage Overview

Customised colour & materials palette for individual towns. Example shown uses Pantone 138C with brass.



Example shows Yarrowonga from Moira, but can be customised across any town/municipality.

Individual Towns

Customised colour and materials palette for individual towns

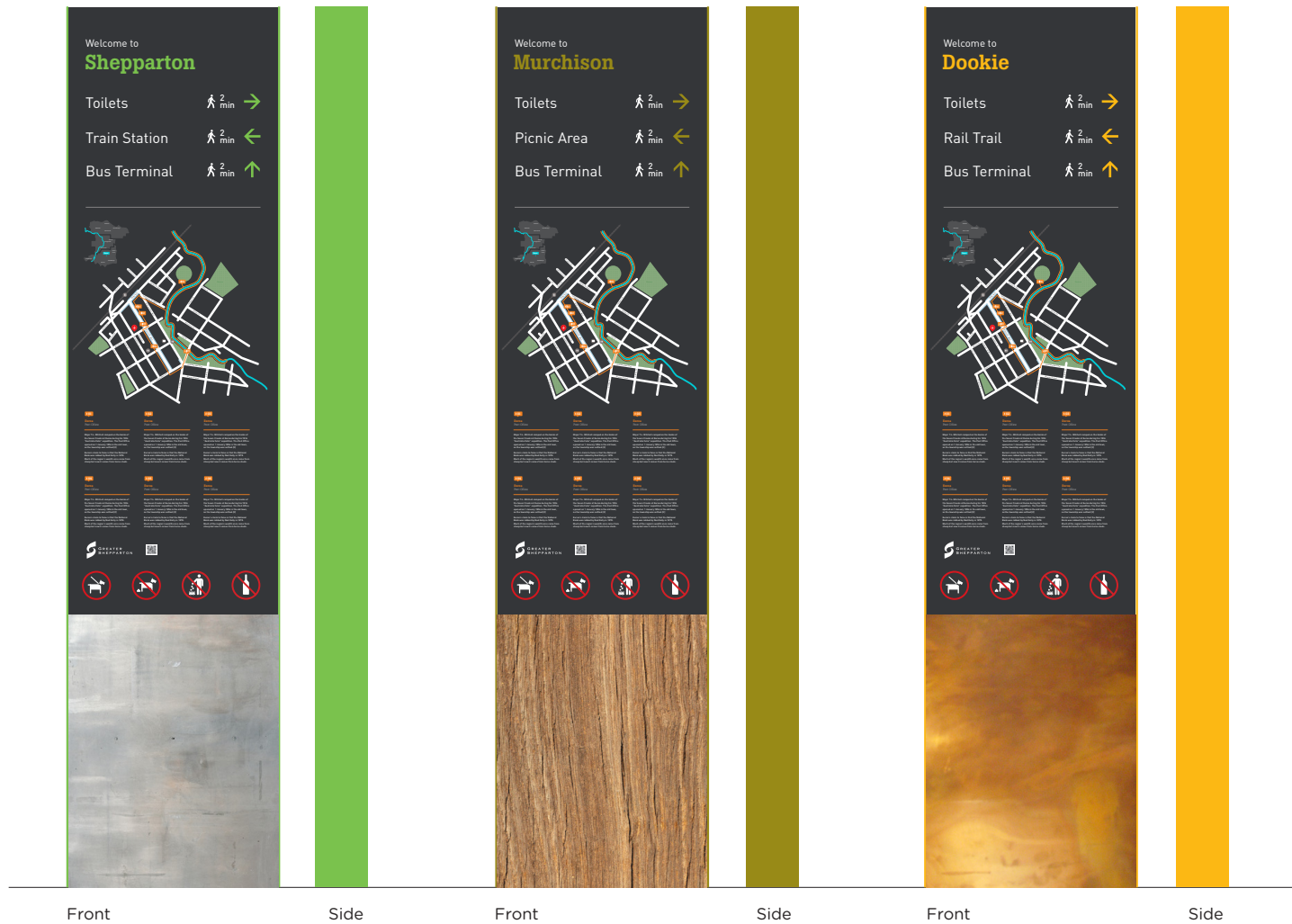

Individual Towns

Customised colour and materials palette for individual towns

Examples show towns from Strathbogie, but can be customised across any town/municipality.

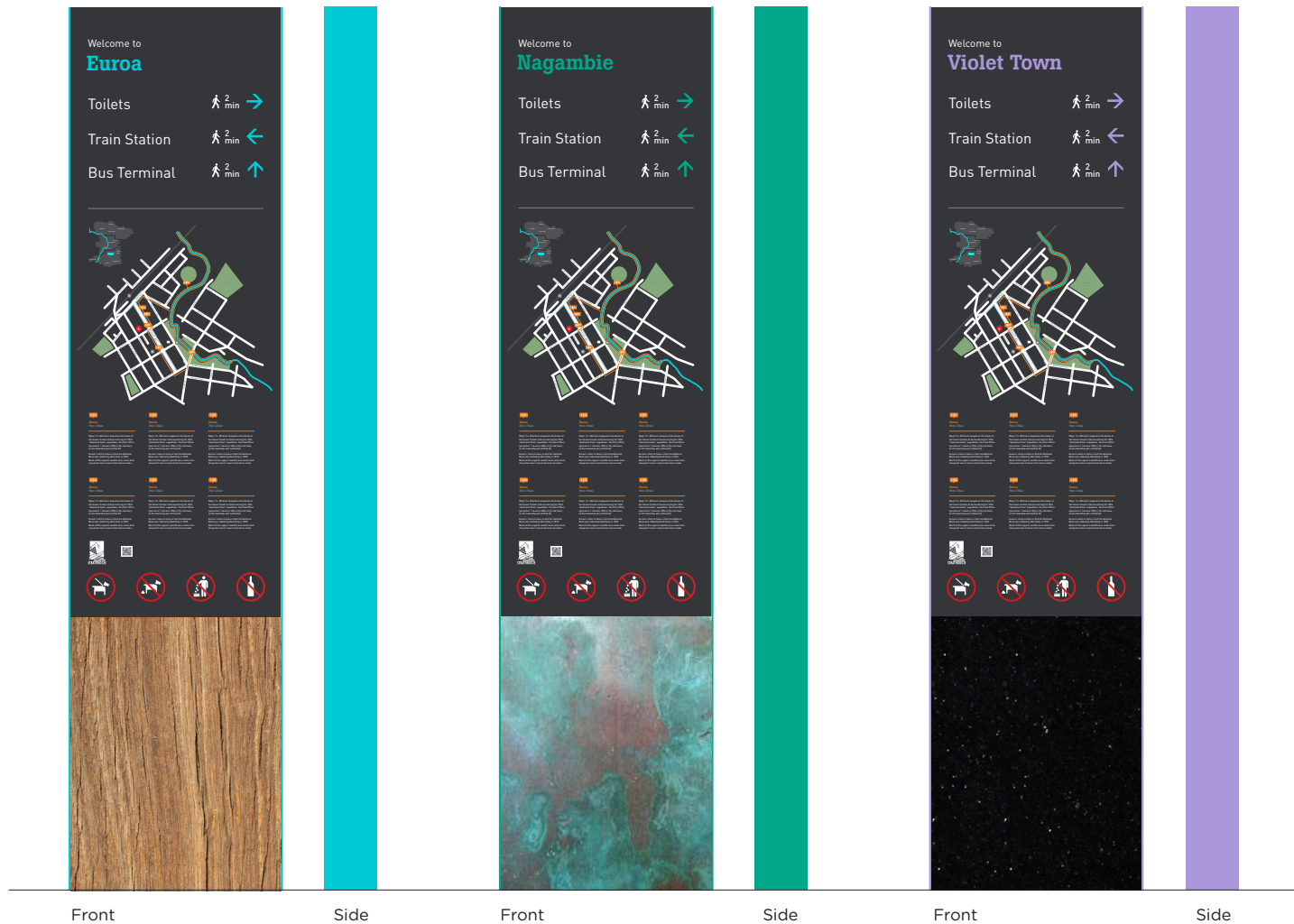

Front

Side

Front

Side

Front

Side

Individual Towns

Customised colour and materials palette for individual towns

Examples show towns from Moira, but can be customised across any town/municipality.



Front

Side



Front

Side



Front

Side

Signage Types Plinth (front)

Plinth Dimensions (mm)
W = 500 H = 2100 D = 125

Text Height
optimised for viewing up to 10m

30mm ↓

Text Height
optimised for viewing up to 6m

20mm ↓



Signage Types Plinth (back)

Large Cities



Towns

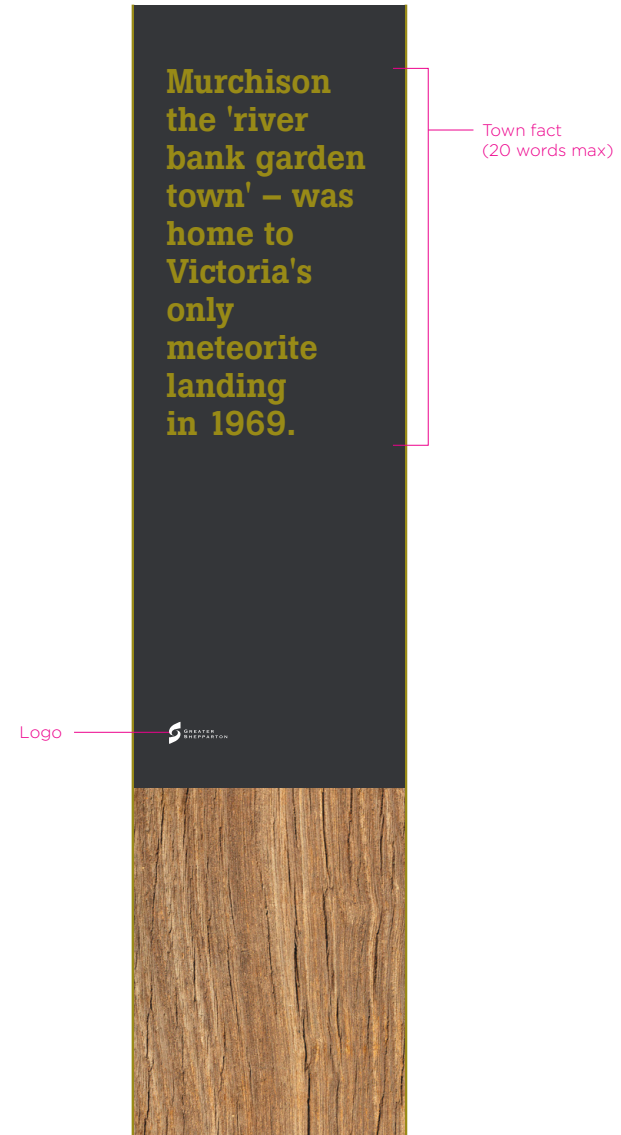

Signage Types Finger Board

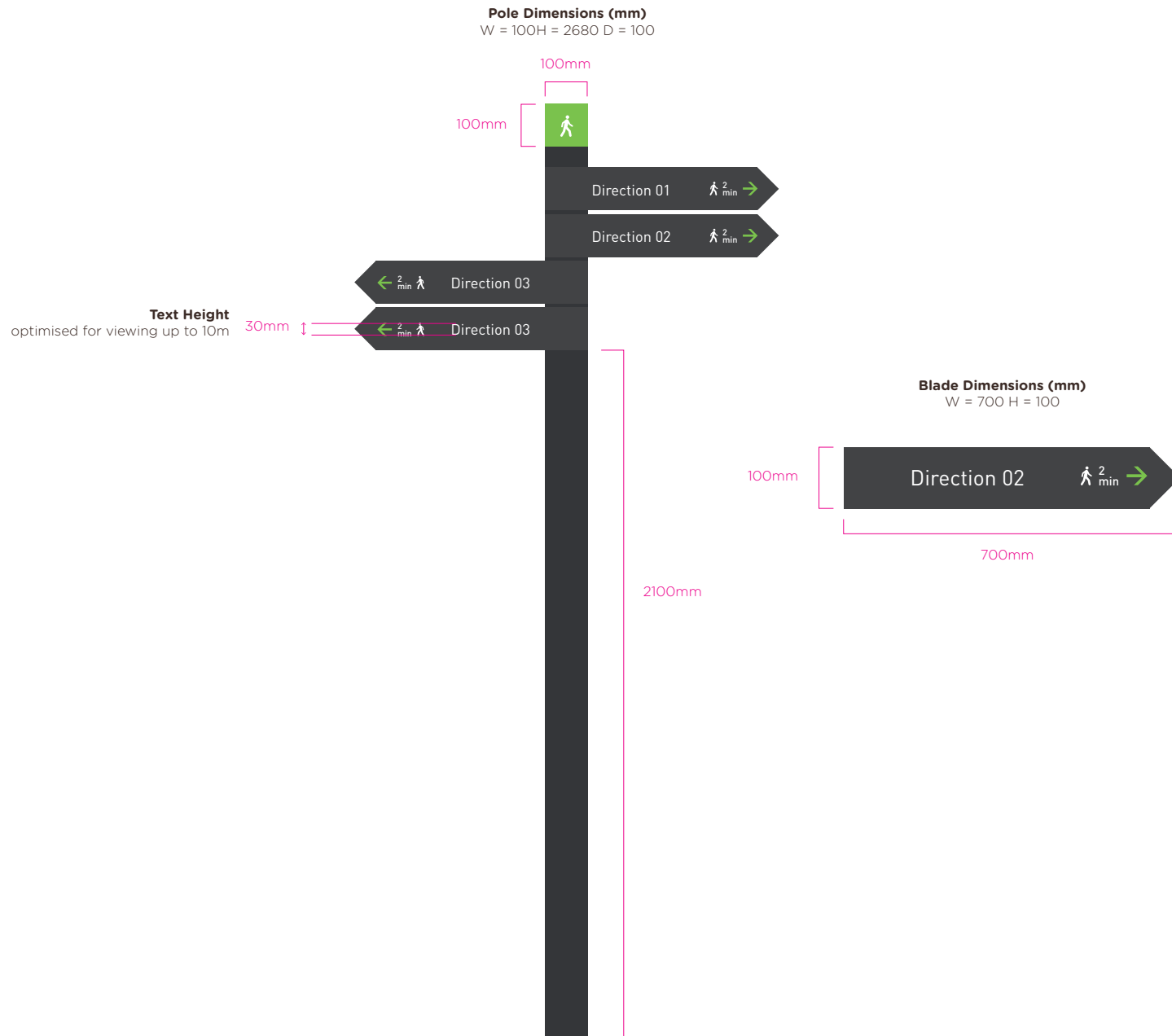

Signage Types Site Identification

Site identification Dimensions (mm)
W = 1100 H = 700 D = 125

Text Height
optimised for viewing up to 20m

70mm



**Shepparton
Library**



Signage Types Trail Marker

Trail Marker Dimensions (mm)
W = 200 H = 800

Text Height
optimised for viewing up to 10m

30mm ↓

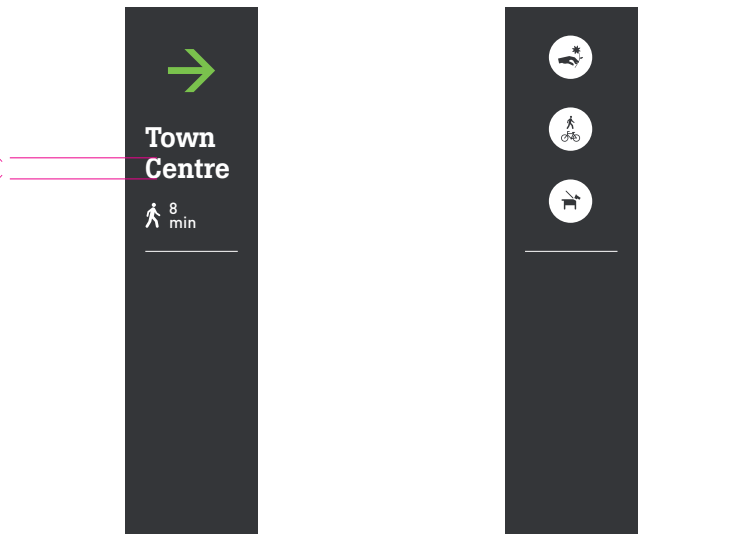

04

Installation & Maintenance

City of Greater Shepparton

Overview

Principles for Placement

Appropriate usage for Signage Family

Installation Guide

Maintenance

Principles of Placement

Placement of signage requires careful consideration and should take into account:

1. Legibility

Consider the audience (vehicle, pedestrian, cyclist) with regard to the viewing distance and speed at which the signs will be viewed.

2. Accessibility

Ensure the signage is situated at appropriate heights and locations to allow for users of varying capacities. Avoid physical obstructions like overhanging vegetation or street furniture.

3. Orientation

Place signs to maximise legibility and accessibility and have the highest visual impact for visitors.

Factors to consider:

- » Position signs free of visual obstructions and in optimum sight lines.
- » Place wayfinding signage at key decision points and locations that are will access the largest audience eg train stations, malls, public facilities.
- » Over signing can be confusing and discouraging for users.
- » Remove obsolete or redundant signage.
- » Consider the hierarchy of signage when signing a walk or trail.
- » An appropriately sited sign should be obvious but not dominant.
- » Be conscious of the scale of neighbouring elements eg buildings, so as not to reduce the signs perceived scale.

Siting considerations

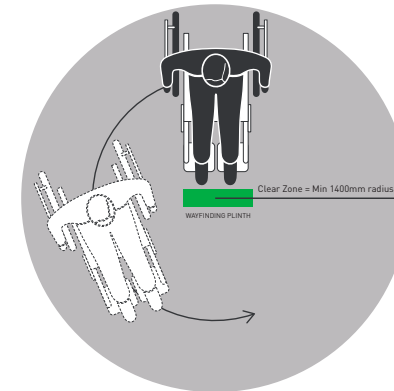

1000mm clearance around plinths

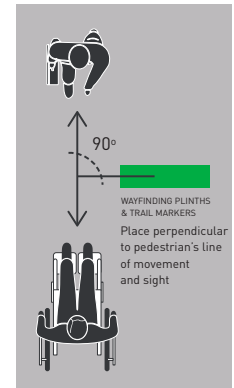

Perpendicular placement of plinths

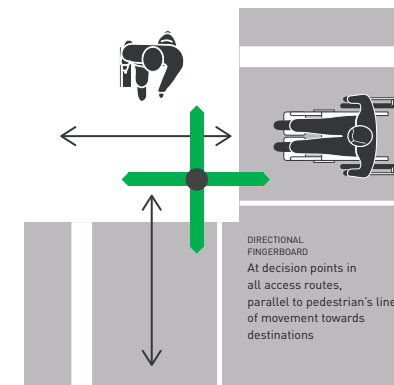

Siting fingerboards

Appropriate usage of sign family

Plinths

Are to be used at key information nodes eg train stations, town parks and town shopping precincts.

They provide viewers directional, orientation (maps), historical and regulatory information. The placement of plinths should consider 'access for all' standards, be located perpendicular to pedestrian movement and sited with suitable clearances to allow wheelchair circulation around the sign.

Plinths should also be located on even ground with a surrounding surface suitable for wheelchair access and with a continuous accessible path of travel which leads up to the plinth. A minimum of 1000 mm clearance is required for wheelchair circulation around plinths (refer to Australian Standards 1428.2).

Fingerboards

Offer an effective and affordable network of directional information in support of the key information nodes (plinths). Finger boards should be located at street or trail intersections, visible for pedestrians, cyclists and vehicles to easily access visually. Finger boards should be sited in locations on access for all routes where possible.

Site Identification Signs

These are destination signs used to identify facilities and places of interest. Directional signs point to these destinations. Should be located at arrival points or adjacent to the entrance to facilities eg. libraries or historical buildings

Trail Markers

Are directional signs used primarily for trails but can be used in towns to direct to key destinations and places of interest. They are an affordable alternative to fingerboards but have less directional choices. Trail markers should be located at key decision points and along trails and walks to instil assurance in users that they are on the right path.

Installation

Installation of signage should be undertaken by an appropriately qualified contractor. If installation is to be carried out by Council, it is important that the relevant structural specifications eg. footing sizes are followed. Please refer to the attached documentation for signage specifications.

Transport of new signage:

- » Ensure delivery of signage from fabricators is undertaken with the utmost care to avoid damage.
- » Signage should be bubble wrapped or similarly protected to avoid dents and scratches.
- » Check all new signs on delivery to ensure no damage was incurred in transit.

Storage:

- » Signage should be stored in a safe place prior to installation and not layed flat where panels can be damaged.
- » Ensure all protective coatings have been applied as per the manufacturers specifications.
- » Site safety
- » Ensure all relevant traffic and pedestrian safety requirements are in place during installation to avoid falls and injuries.
- » Remember that a sign itself may be a hazard. Place signs so that they do not obscure hazards or distract the viewer during hazardous situations.

Maintenance

Signage should always be well maintained to project a positive image of Council and the community. To achieve this, signs require regular inspections and upkeep.

A regular inspection program should look for:

- » the sign has not been tampered with or vandalised
- » the relevance of the information
- » the condition of the finishes and materials
- » the presence of any obstructions
- » all fixings are tight and present

Make sure the information on signage is relevant and the sign is functioning as it was originally intended. Things change, so signage should reflect the changes that happen and be up to date and relevant.

05

Technical Specifications

City of Greater Shepparton

Overview

Plinth

Site Identification

Directional Fingerboard

Trail Marker

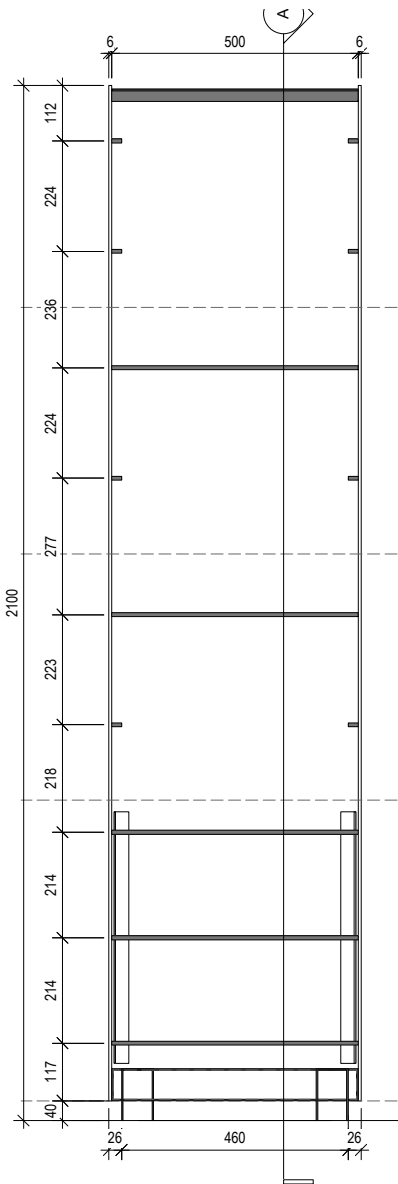

1 FRAME STRUCTURAL SCHEME
Scale: 1:10

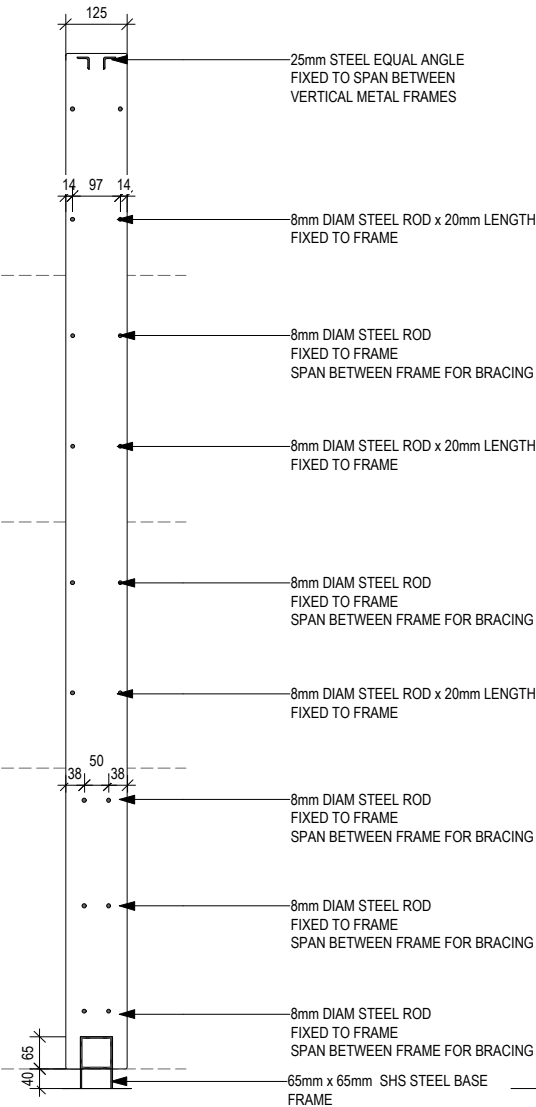

2 SECTION A
Scale: 1:10



2 TYPICAL PLINTH FRONT VIEW
Scale: 1:10

NOTE:
FOR FOOTING DESIGN REFER TO ENGINEERING DRAWINGS

GENERAL NOTE:
1. 2mm FOAM TAPE WHEREVER ENAMEL TOUCHES ENAMEL OR STEEL.

2. 2mm RUBBER GASQUET EVA FOAM TO BE FITTED BETWEEN SIGNAGE PANELS WHEN FIXED TO INTERNAL CHANNEL OR FRAME.

3. ALL SAFETY FIXINGS INSTALLED WITH GRAPHITE POWDER OR LUBRICANT.

NOTE ON COLD GAL:
ALL COLD GALVANISING SHALL BE PREMIXED ORGANIC ZINC COMPOUND WITH THE FOLLOWING PROPERTIES:

1. METALLIC ZINC CONTENT 95% BY WEIGHT BY VOLUME.
2. SOLIDS CONTENT 52% BY WEIGHT BY VOLUME.
3. MINIMUM APPLICATION RATE 1.5mils DRY FILM THICKNESS PER COAT.
4. MINIMUM NUMBER OF COATS 2.

NOTE ON FINISHED ARTWORK
TO BE SUPPLIED BY OTHER.

Be aware of underground services. The locations of underground services are indicative only. Their exact position to be proved on site.
Contractor to verify all dimensions on site before commencing work. Report all discrepancies to equipment prior to construction. Final dimensions and vertical joint locations to be taken in preference to scaled drawings. All drawings may not be reproduced or distributed without prior permission from the author. Check all dimensions and site conditions prior to commencement of any work, the purchasing or ordering of any materials, fitting, plant services or equipment and the fabrication of any components.

REV	DATE	AMENDMENTS
C1	04/05/2012	For Construction
C2	17/09/2012	For Construction

REV	DATE	AMENDMENTS

REV	DATE	AMENDMENTS

Landmark Architect
ASPECT Studios
30-32 Lacey Street
Cobram VIC 3380
1300 947 1484

ASPECT Studios
PROFESSIONAL ARCHITECTURE AND DESIGN SERVICES

Melbourne

PROJECT
Goulburn Valley Signage Strategy

CLIENT
Melbourne

STATUS

DRAWING TITLE			
TYPICAL PLINTH FRAMING			
DRAWN	CHECKED	SCALE	DATE
KG/AW	IR	A3 AS SHOWN	10/04/2013
DRAWING NO.			REV

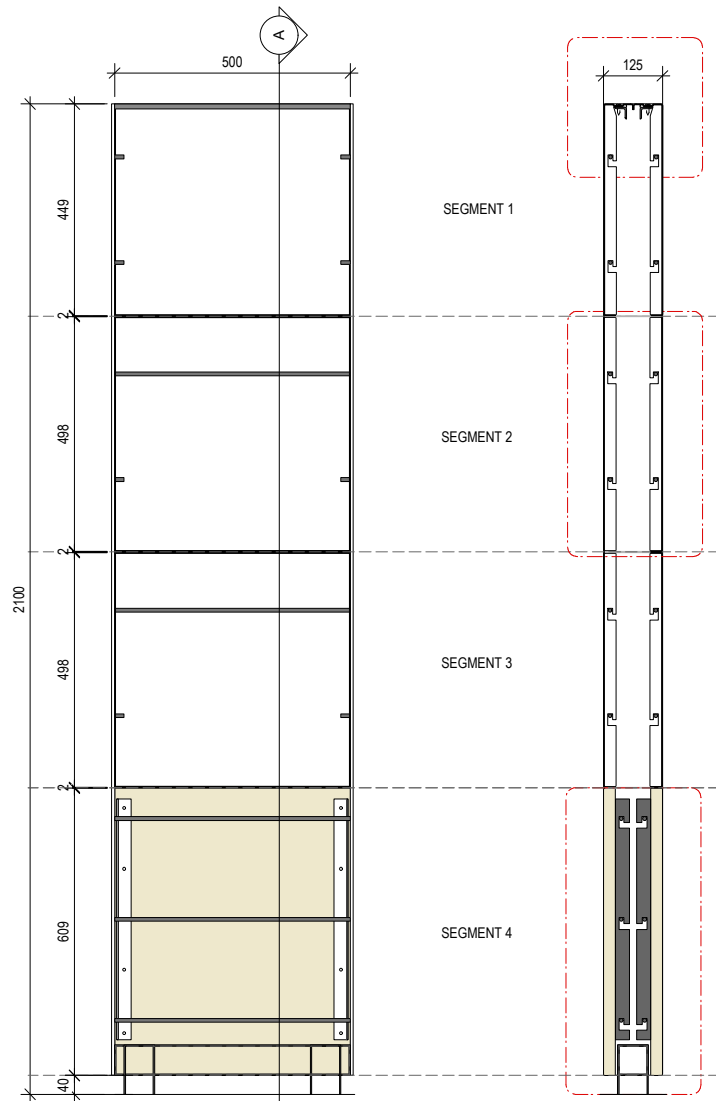

1 FRAME SCHEME
Scale: 1:10

2 SECTION A
Scale: 1:10

FOR TYPE 1A PANELS WHERE MATERIAL IS 25mm THICK:
 Timber- Spotted Gum
 Timber- Cyprus Pine
 Stone- Sandstone
 Compressed Fibre Cement Sheet
 Timber- Red Gum

NOTE:
FOR FOOTING DESIGN REFER TO ENGINEERING DRAWINGS



3 FRONT ELEVATION
Scale: 1:10

GENERAL NOTE:
 1. 2mm FOAM TAPE WHEREVER ENAMEL TOUCHES ENAMEL OR STEEL.
 2. 2mm RUBBER GASQUET EVA FOAM TO BE FITTED BETWEEN SIGNAGE PANELS WHEN FIXED TO INTERNAL CHANNEL OR FRAME.
 3. ALL SAFETY FIXINGS INSTALLED WITH GRAPHITE POWDER OR LUBRICANT.

NOTE ON COLD GAL:
 ALL COLD GALVANISING SHALL BE PREMIXED ORGANIC ZINC COMPOUND WITH THE FOLLOWING PROPERTIES:
 1. METALLIC ZINC CONTENT 95% BY WEIGHT BY VOLUME.
 2. SOLIDS CONTENT 52% BY WEIGHT BY VOLUME.
 3. MINIMUM APPLICATION RATE 1.5mls DRY FILM THICKNESS PER COAT.
 4. MINIMUM NUMBER OF COATS 2.

NOTE ON FINISHED ARTWORK
 TO BE SUPPLIED BY OTHER.

Review of underground services. The locations of underground services are indicative only. Their exact position to be proven on site. Contractor to verify all dimensions on site before commencing work. Report all discrepancies to superintendent prior to construction. Figure dimensions and actual point coordinates to be taken in accordance to latest drawings. All fixings may be pre-ordered or distributed without prior purchase from the landscape architect. Check all dimensions and site conditions prior to commencement of any work, the purchasing or ordering of any materials, fixing, plant services or equipment and the fabrication of any components.		KEY [Empty grid for key]		REV. DATE AMENDMENTS C1 05/09/2012 For Construction C2 17/09/2012 For Construction	REV. DATE AMENDMENTS [Empty]	REV. DATE AMENDMENTS [Empty]	Landscape Architect ASPECT Studios 20/21 Lane Street Melbourne VIC 3000 T 03 9517 8844	ASPECT Studios Melbourne Street Signage Melbourne	PROJECT Goulburn Valley Signage Strategy	DRAWING TITLE TYPE 1 A PLINTH	DRAWN KG/AW	CHECKED IR	SCALE A3 AS SHOWN	DATE 10/04/2013	REV C2
Civil & Structural							CLIENT City of Greater Shepparton		STATUS DRAFT	DRAWING NO. M12073-LA-02					

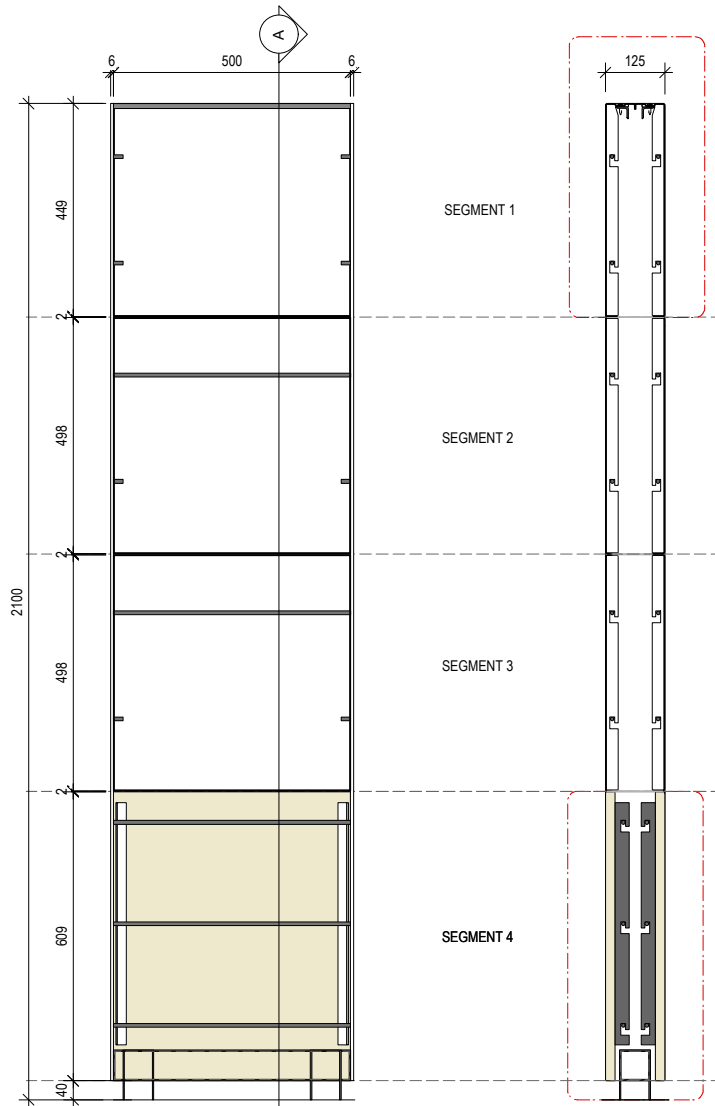

1 FRAME SCHEME
Scale: 1:10

2 SECTION A
Scale: 1:10

FOR TYPE 1B PANELS WHERE
MATERIAL IS 20mm THICK:
Stone- Blue Stone
Stone- Granite

NOTE:
FOR FOOTING DESIGN REFER TO ENGINEERING DRAWINGS

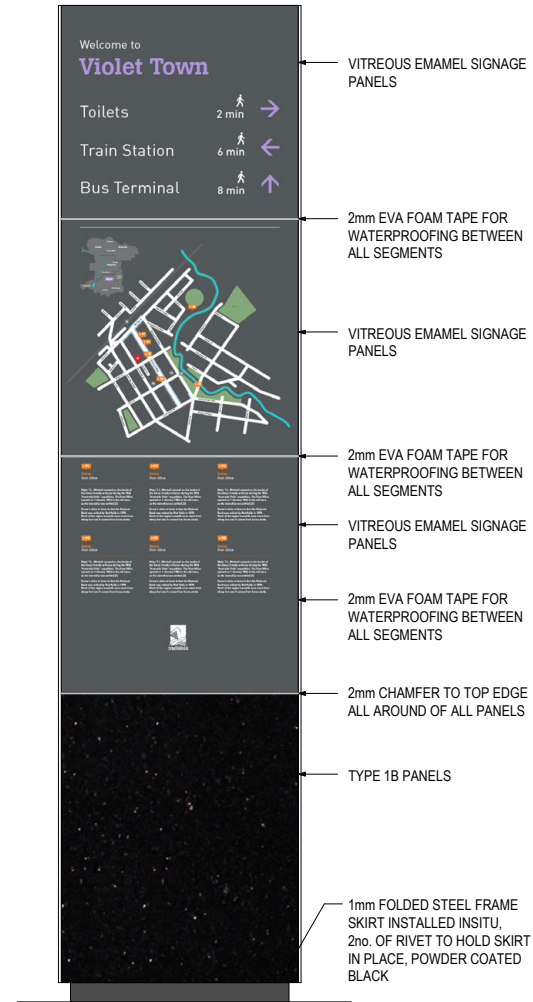

3 FRONT ELEVATION
Scale: 1:10

GENERAL NOTE:
1. 2mm FOAM TAPE WHEREVER ENAMEL TOUCHES ENAMEL OR STEEL.

2. 2mm RUBBER GASQUET EVA FOAM TO BE FITTED BETWEEN SIGNAGE PANELS WHEN FIXED TO INTERNAL CHANNEL OR FRAME.

3. ALL SAFETY FIXINGS INSTALLED WITH GRAPHITE POWDER OR LUBRICANT.

NOTE ON COLD GAL:
ALL COLD GALVANISING SHALL BE PREMIXED ORGANIC ZINC COMPOUND WITH THE FOLLOWING PROPERTIES:

1. METALLIC ZINC CONTENT 95% BY WEIGHT BY VOLUME.

2. SOLIDS CONTENT 52% BY WEIGHT BY VOLUME.

3. MINIMUM APPLICATION RATE 1.5mls DRY FILM THICKNESS PER COAT.

4. MINIMUM NUMBER OF COATS 2.

NOTE ON FINISHED ARTWORK
TO BE SUPPLIED BY OTHER.

REV.	DATE	AMENDMENTS	REV.	DATE	AMENDMENTS
C1	05/06/2012	For Construction			
C2	17/06/2012	For Construction			

Landscape Architect ASPECT Studios 20/12 Corner Street Melbourne VIC 3005 T:03 9417 8844	ASPECT Studios Melbourne	PROJECT Goulburn Valley Signage Strategy	DRAWING TITLE TYPE 1B PLINTH
CLIENT City of Greater Shepparton	STATUS DRAFT	DRAWN KGI/AW	CHECKED JR
		SCALE AS SHOWN	DATE 10/04/2013
		DRAWING NO. M12073-LA-03	REV C2

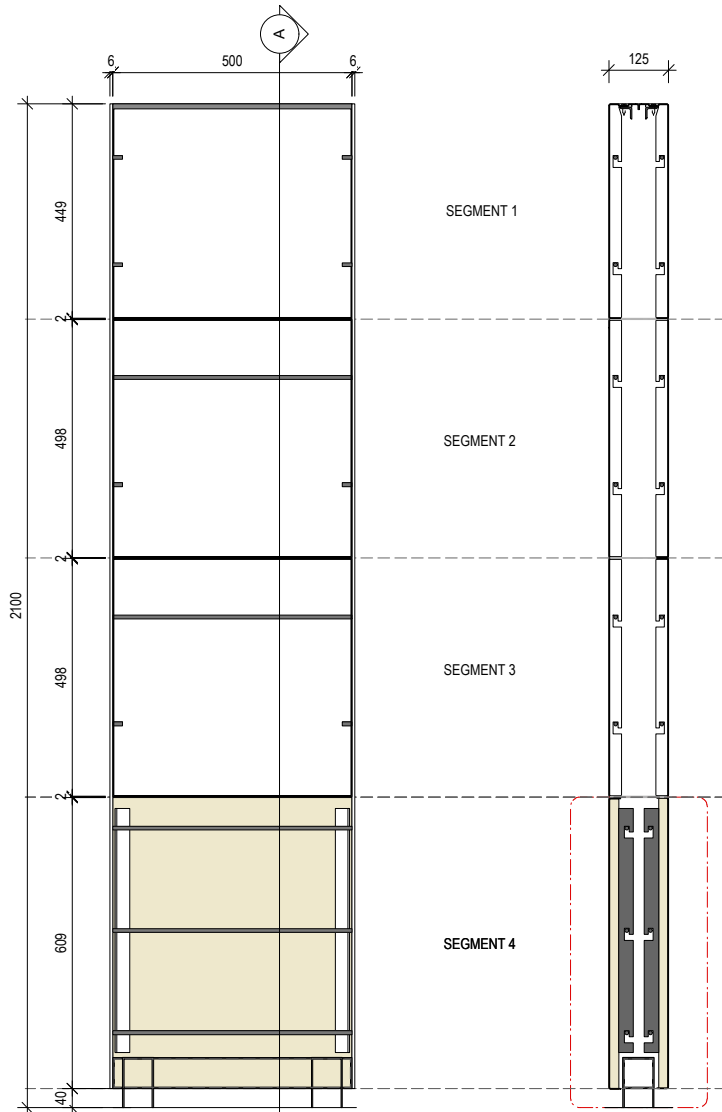

1 FRAME SCHEME
Scale: 1:10

2 SECTION A
Scale: 1:10

FOR TYPE 2 PANELS WHERE MATERIAL IS 1.6mm THICK MOUNTED ON 19mm THICK MARINE PLYWOOD:
Copper Panel- Larsons Metal Copper
Copper Panel- Aged Patina
Brass Panel- Metals Brass
Painted Steel - Dulux WEATHERMAX HBR

NOTE:
FOR FOOTING DESIGN REFER TO ENGINEERING DRAWINGS



3 FRONT ELEVATION
Scale: 1:10

GENERAL NOTE:
1. 2mm FOAM TAPE WHEREVER ENAMEL TOUCHES ENAMEL OR STEEL.

2. 2mm RUBBER GASQUET EVA FOAM TO BE FITTED BETWEEN SIGNAGE PANELS WHEN FIXED TO INTERNAL CHANNEL OR FRAME.

3. ALL SAFETY FIXINGS INSTALLED WITH GRAPHITE POWDER OR LUBRICANT.

NOTE ON COLD GAL:
ALL COLD GALVANISING SHALL BE PREMIXED ORGANIC ZINC COMPOUND WITH THE FOLLOWING PROPERTIES:

1. METALLIC ZINC CONTENT 95% BY WEIGHT BY VOLUME.

2. SOLIDS CONTENT 52% BY WEIGHT BY VOLUME.

3. MINIMUM APPLICATION RATE 1.5mls DRY FILM THICKNESS PER COAT.

4. MINIMUM NUMBER OF COATS 2.

NOTE ON FINISHED ARTWORK
TO BE SUPPLIED BY OTHER.

Review of underground services. The locations of underground services are indicative only. Their exact positions to be proven on site. Consider to verify all dimensions on site before commencing work. Report all discrepancies to superintendent prior to construction. Fix and correct dimensions and record point coordinates to be taken in preference to similar drawings. All drawings may not be reproduced or distributed without prior permission from the landscape architect. Check all dimensions and site conditions prior to commencement of any work, the purchasing or ordering of any materials, fitting plant services or equipment and the fabrication of any components.	REV	DATE	AMENDMENTS	REV	DATE	AMENDMENTS	Landscape Architect ASPECT Studios 20-22 Esplanade Camberwell VIC 3163 T: 03 9517 6844	 Melbourne	PROJECT Goulburn Valley Signage Strategy	DRAWING TITLE TYPE 2 PLINTH			
	C1	05/06/2012	For Construction								DRAWN KGI/AV	CHECKED IR	SCALE A3 AS SHOWN
									CLIENT City of Greater Shepparton	STATUS DRAFT	DRAWING NO. M12073-LA-04		

NOTE:
FOR FOOTING DESIGN REFER TO ENGINEERING DRAWINGS

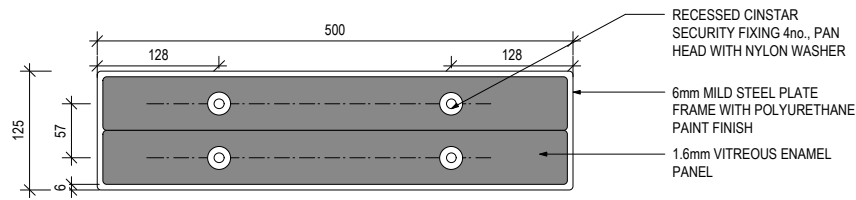

A TYPICAL PLAN DETAIL SEGMENT 1 FIXING - Plinth
Scale: 1:5

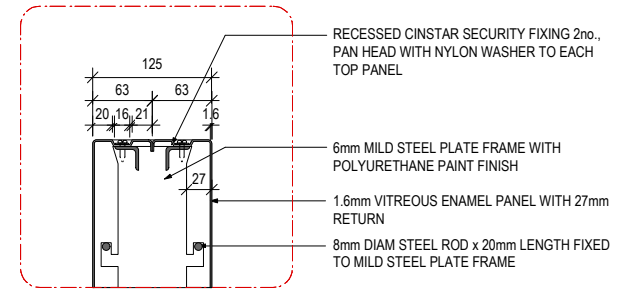

B SECTION DETAIL SEGMENT 1 FIXING- Plinth
Scale: 1:5

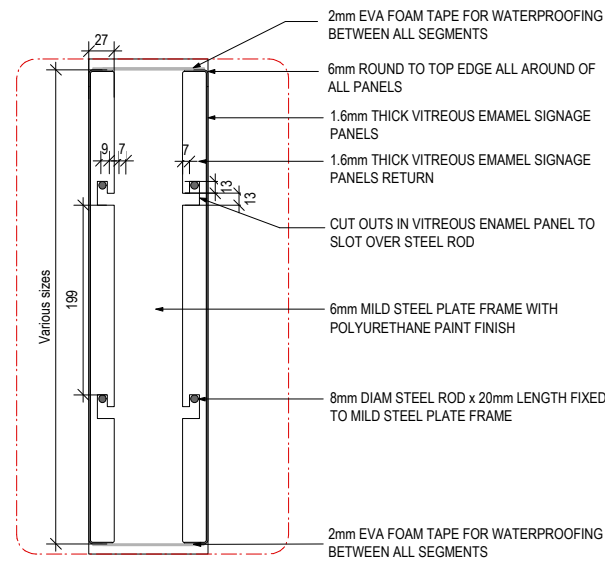

C TYPICAL PANEL DETAIL SEGMENTS 1,2,3 - Plinth
Scale: 1:5

<p>Review of underground services. The locations of underground services are indicative only. Their exact position to be proven on site.</p> <p>Consent to verify all dimensions on site before commencing work. Report all discrepancies to superintendent prior to construction. Figure dimensions and exact point coordinates to be taken in accordance to building drawings. All drawings may not be reproduced or distributed without prior permission from the landscape architect. Check all dimensions and site conditions prior to commencement of any work. The purchasing or ordering of any materials, fitting, plant services or equipment and the fabrication of any components.</p>	KEY	REV.	DATE	AMENDMENTS	REV.	DATE	AMENDMENTS	<p>Landscaping Architect ASPECT Studios 30-32 Leany Street Collingwood VIC 3068 03 9417 6844</p>	<p>ASPECT Studios™ LANDSCAPE ARCHITECTS Melbourne</p>	<p>PROJECT Goulburn Valley Signage Strategy</p>	DRAWING TITLE PLINTH FRAME DETAILS			
		C1	05/06/2012	For Construction								<p>CLIENT City of Greater Shepparton</p>	<p>STATUS DRAFT</p>	<p>DRAWN KG/AW</p>

NOTE:
FOR FOOTING DESIGN REFER TO ENGINEERING DRAWINGS

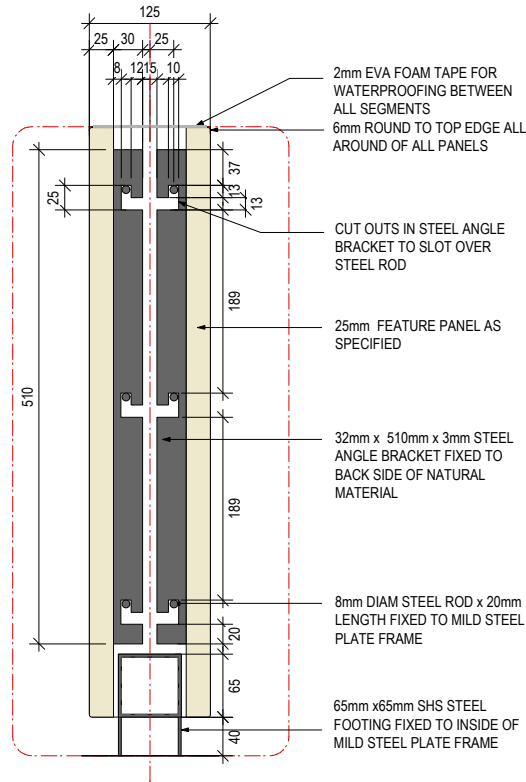

A DETAIL TYPE 1A PANEL SEGMENT 4 - Plinth
Scale: 1:5

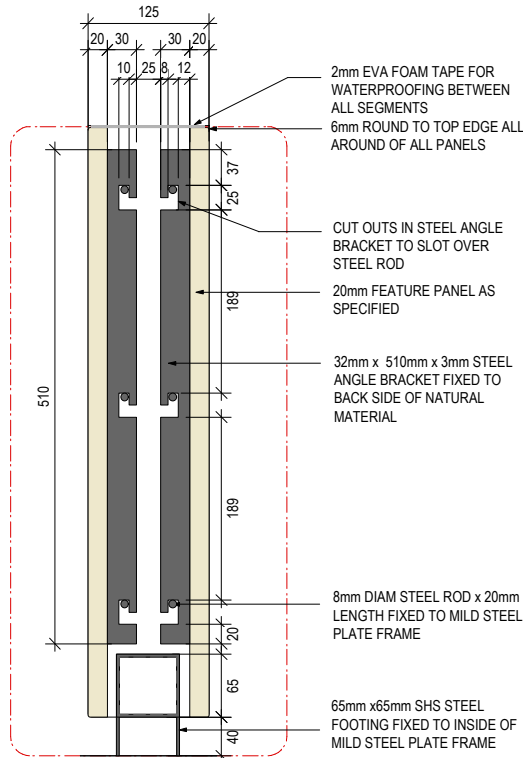

B DETAIL TYPE 1B PANEL SEGMENT 4 - Plinth
Scale: 1:5

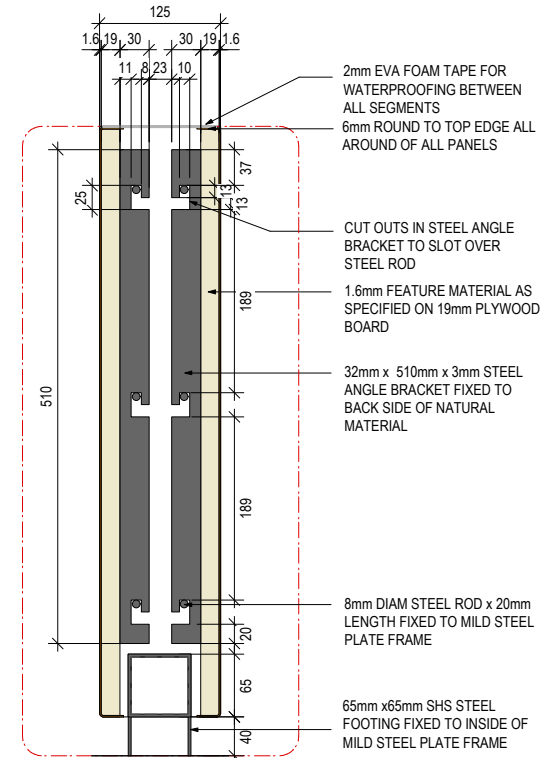

C DETAIL TYPE 2 PANEL SEGMENT 4 - Plinth
Scale: 1:5

<p>Be aware of underground services. The locations of underground services are indicative only. Their exact position to be proven on site.</p> <p>Contractor to verify all dimensions on site before commencing work. Report all discrepancies to superintendent prior to construction. Firmed dimensions and setout point coordinates to be taken in preference to scaled drawings. All drawings are not to be reproduced or distributed without prior permission from the landscape architect. Check all dimensions and site conditions prior to commencement of any work. The purchasing or ordering of any materials, fittings, plant services or equipment and the fabrication of any components.</p>	KEY	<table border="1"> <thead> <tr> <th>REV.</th> <th>DATE</th> <th>AMENDMENTS</th> <th>REV.</th> <th>DATE</th> <th>AMENDMENTS</th> </tr> </thead> <tbody> <tr> <td>C1</td> <td>05/06/2012</td> <td>For Construction</td> <td></td> <td></td> <td></td> </tr> <tr> <td>C2</td> <td>17/06/2012</td> <td>For Construction</td> <td></td> <td></td> <td></td> </tr> <tr> <td></td> <td></td> <td></td> <td></td> <td></td> <td></td> </tr> <tr> <td></td> <td></td> <td></td> <td></td> <td></td> <td></td> </tr> <tr> <td></td> <td></td> <td></td> <td></td> <td></td> <td></td> </tr> <tr> <td></td> <td></td> <td></td> <td></td> <td></td> <td></td> </tr> <tr> <td></td> <td></td> <td></td> <td></td> <td></td> <td></td> </tr> <tr> <td></td> <td></td> <td></td> <td></td> <td></td> <td></td> </tr> <tr> <td></td> <td></td> <td></td> <td></td> <td></td> <td></td> </tr> <tr> <td></td> <td></td> <td></td> <td></td> <td></td> <td></td> </tr> </tbody> </table>	REV.	DATE	AMENDMENTS	REV.	DATE	AMENDMENTS	C1	05/06/2012	For Construction				C2	17/06/2012	For Construction																																																				<p>Landscaping Architect ASPECT Studios 20-32 Erney Street Colingwood VIC 3093 T: 03 94713844</p> <p>ASPECT Studios™ LANDSCAPE ARCHITECTS Melbourne</p>	<p>PROJECT Goulburn Valley Signage Strategy</p> <p>CLIENT City of Greater Shepparton</p> <p>STATUS DRAFT</p>	<p>DRAWING TITLE SMALL MAPPED PLINTH</p> <table border="1"> <tr> <td>DRAWN KGA/JAW</td> <td>CHECKED JR</td> <td>SCALE A3 AS SHOWN</td> <td>DATE 10/04/2013</td> </tr> </table> <p>DRAWING NO. M12073-LA-06</p> <p>REV C2</p>	DRAWN KGA/JAW	CHECKED JR	SCALE A3 AS SHOWN	DATE 10/04/2013
	REV.	DATE	AMENDMENTS	REV.	DATE	AMENDMENTS																																																																					
C1	05/06/2012	For Construction																																																																									
C2	17/06/2012	For Construction																																																																									
DRAWN KGA/JAW	CHECKED JR	SCALE A3 AS SHOWN	DATE 10/04/2013																																																																								

NOTE:
FOR FOOTING DESIGN REFER TO ENGINEERING DRAWINGS

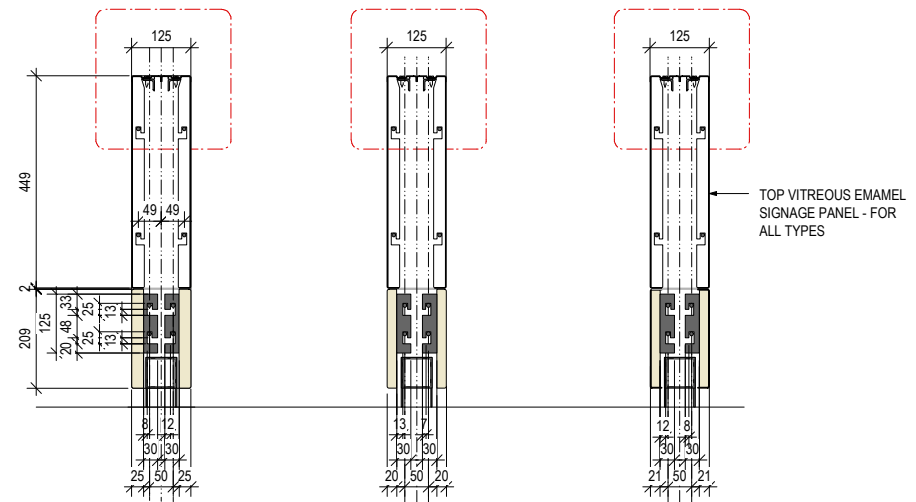
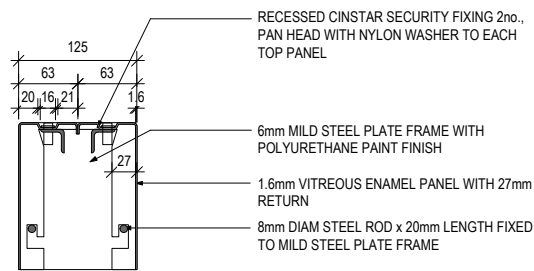
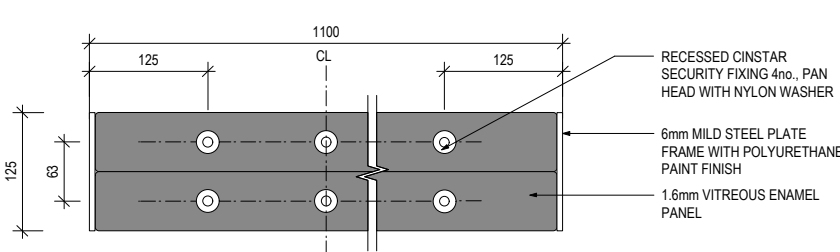
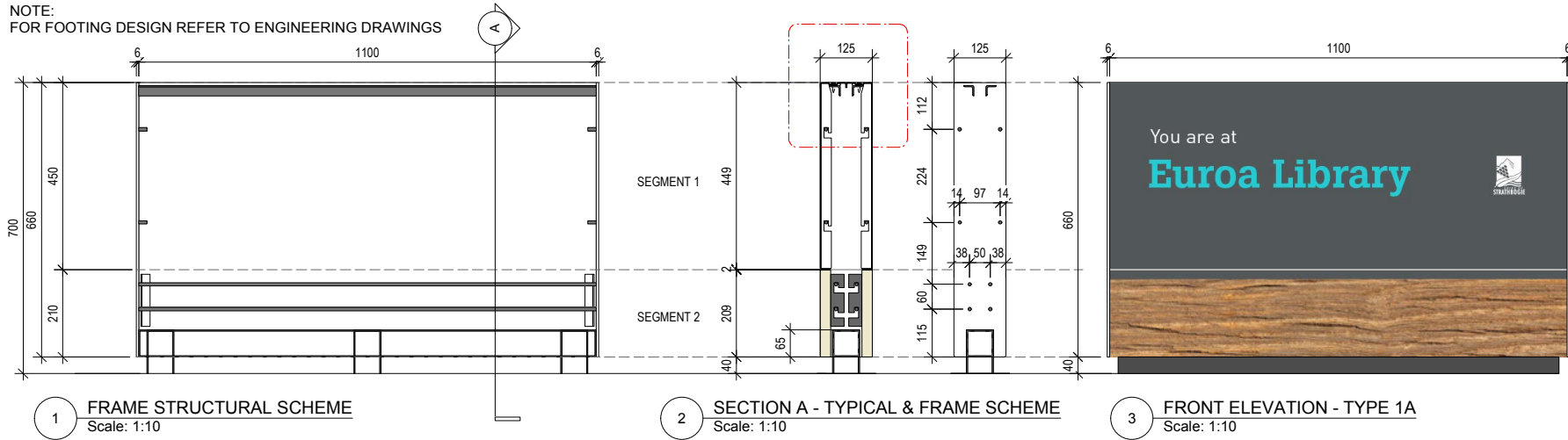

Beware of underground services. The locations of underground services are indicative only. Their exact position to be proven on site. Consider to verify all dimensions on site before commencing work. Report all discrepancies to superintendent prior to construction. Figure dimensions and actual point coordinates to be taken in accordance to latest drawings. All drawings may not be reproduced or distributed without prior permission from the landscape architect. Check all dimensions and site conditions prior to commencement of any work, the purchasing or ordering of any materials, fitting plant services or equipment and the fabrication of any components.	KEY	REV. DATE AMENDMENTS	REV. DATE AMENDMENTS	Landscape Architect ASPECT Studios 20-22 Green Street Melbourne VIC 3008 T: 03 9611 8888	PROJECT Goulburn Valley Signage Strategy	DRAWING TITLE SMALL PLINTH							
	<table border="1"> <tr> <th>DRAWN</th> <th>CHECKED</th> <th>SCALE</th> <th>DATE</th> </tr> <tr> <td>KGS/AW</td> <td>IR</td> <td>AS SHOWN</td> <td>10/04/2013</td> </tr> </table>	DRAWN	CHECKED	SCALE	DATE	KGS/AW	IR	AS SHOWN	10/04/2013	<table border="1"> <tr> <th>DRAWING NO.</th> <th>REV</th> </tr> <tr> <td>M12073-LA-07</td> <td>C2</td> </tr> </table>	DRAWING NO.	REV	M12073-LA-07
DRAWN	CHECKED	SCALE	DATE										
KGS/AW	IR	AS SHOWN	10/04/2013										
DRAWING NO.	REV												
M12073-LA-07	C2												
				CLIENT City of Greater Shepparton	STATUS DRAFT								

NOTE:
FOR FOOTING DESIGN REFER TO ENGINEERING
DRAWINGS

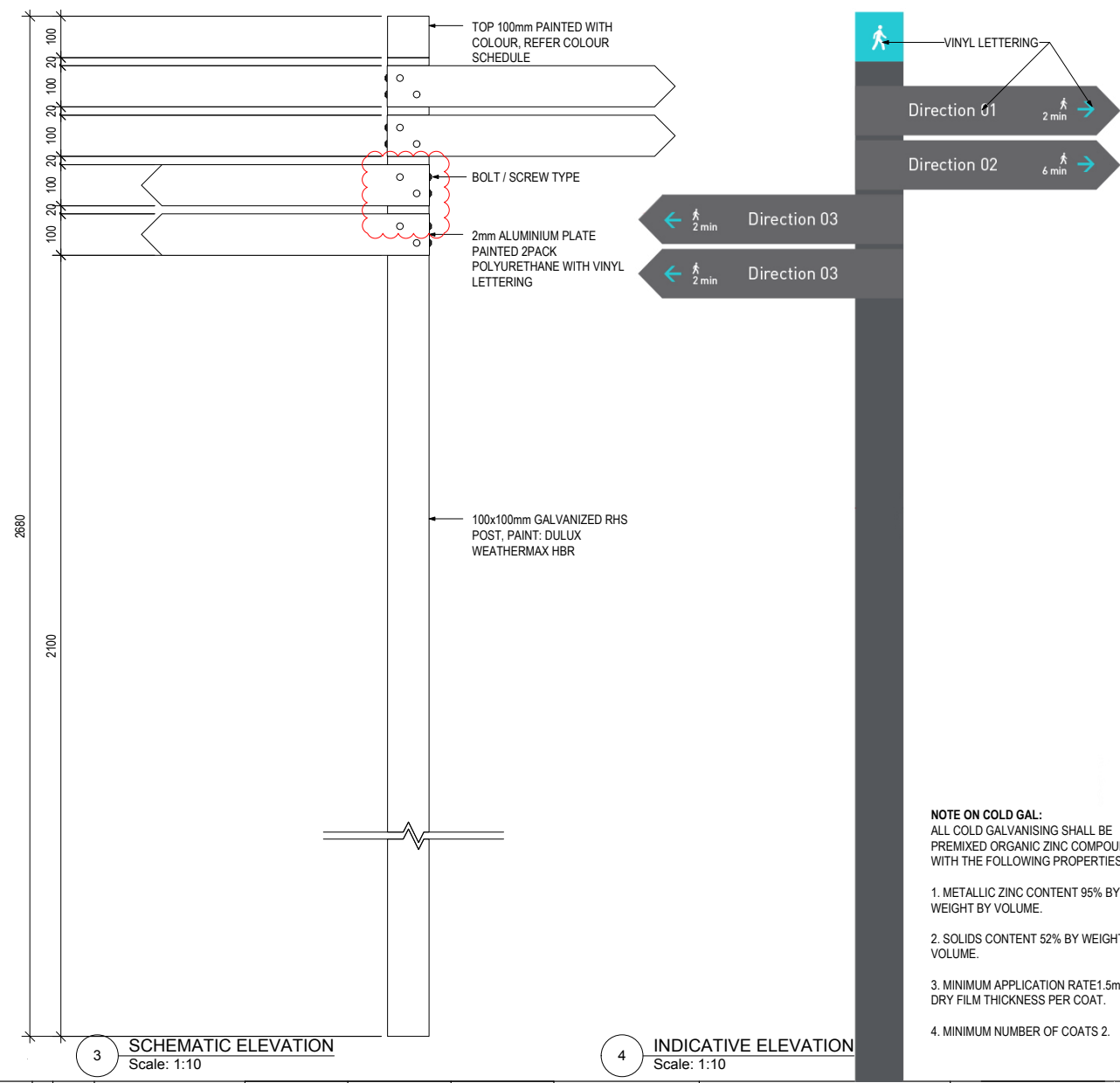

NOTE ON COLD GAL:
ALL COLD GALVANISING SHALL BE PREMIXED ORGANIC ZINC COMPOUND WITH THE FOLLOWING PROPERTIES:

- METALLIC ZINC CONTENT 95% BY WEIGHT BY VOLUME.
- SOLIDS CONTENT 52% BY WEIGHT BY VOLUME.
- MINIMUM APPLICATION RATE 1.5mls DRY FILM THICKNESS PER COAT.
- MINIMUM NUMBER OF COATS 2.

3 SCHEMATIC ELEVATION
Scale: 1:10

4 INDICATIVE ELEVATION
Scale: 1:10

Review of underground services. The locations of underground services are indicative only. Their exact position to be proven on site. Contractor to verify all dimensions on site before commencing work. Report all discrepancies to superintendent prior to construction. Figure dimensions and setout point coordinates to be taken in preference to similar drawings. All drawings may not be reproduced or distributed without prior permission from the landscape architect. Check all dimensions and site conditions prior to commencement of any work, the purchasing or ordering of any materials, hiring plant services or equipment and the fabrication of any components.	KEY	REV.	DATE	AMENDMENTS	REV.	DATE	AMENDMENTS	Landscape Architect ASPECT Studios 20-21 Carey Street Collingwood VIC 3068 T 03 9517 8844		PROJECT Goulburn Valley Signage Strategy	DRAWING TITLE			
												DIRECTIONAL FINGERBOARD DRAWN: KGI/AW CHECKED: JR SCALE: A3 DATE: 10/04/2013 DRAWING NO: M12073-LA-08 REV: C2		
								Client & Structural Lighting	CLIENT City of Greater Shepparton	STATUS DRAFT				

NOTE:
FOR FOOTING DESIGN REFER TO ENGINEERING DRAWINGS

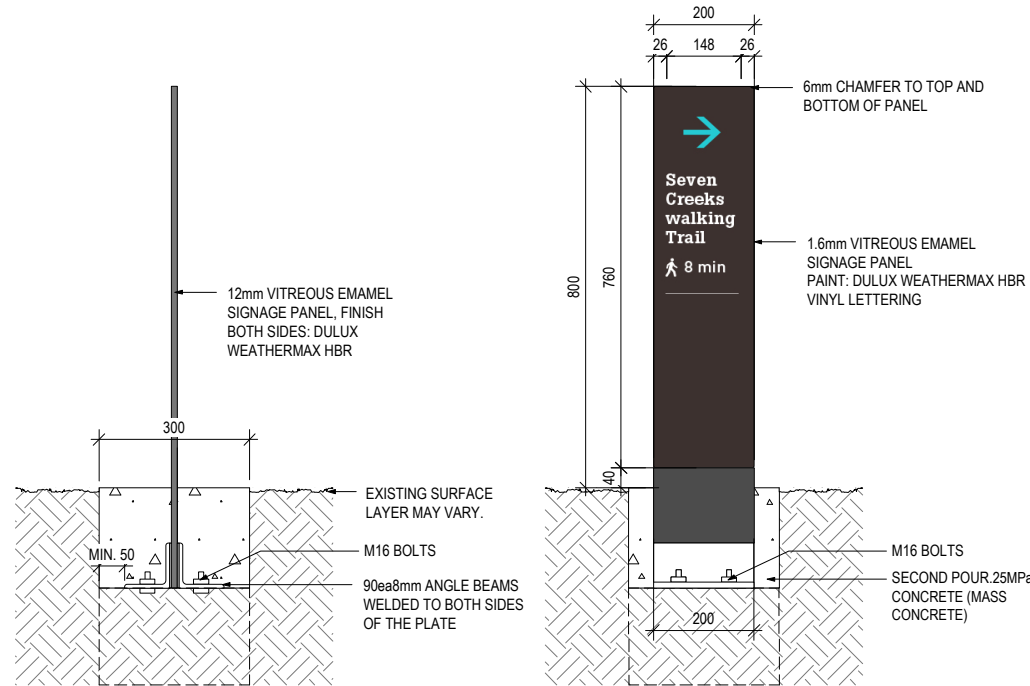

1 SIDE ELEVATION SQUARE FOOTING
Scale: 1:10

2 FRONT ELEVATION SQUARE FOOTING
Scale: 1:10

Be aware of underground services. The locations of underground services are indicative only. Their exact position to be proven on site. Contractor to verify all dimensions on site before commencing work. Report all discrepancies to superintendent prior to construction. Fixeased dimensions and actual point coordinates to be taken in preference to scaled drawings. All drawings may not be reproduced or distributed without prior permission from the landscape architect. Check all dimensions and site conditions prior to commencement of any work, the purchasing or ordering of any materials, fitting, plant services or equipment and the fabrication of any components.	KEY	REV	DATE	AMENDMENTS	REV	DATE	AMENDMENTS	Landscape Architect ASPECT Studios 30/32 Cass Street Coleraine VIC 3096 T 03 9471 9844		PROJECT	DRAWING TITLE			
		C1	05/06/2012	For Construction							Civil & Structural Lighting	Melbourne Goulburn Valley Signage Strategy	DRAWN KG/AW	CHECKED IR

G - GENERAL

- ALL WORK AND MATERIALS SHALL BE IN ACCORDANCE WITH THE DRAWINGS, THE SPECIFICATION, AND CURRENT RELEVANT AUSTRALIAN STANDARDS, THE BUILDING CODE OF AUSTRALIA AND OTHER STATUTORY REQUIREMENTS.
- THESE DRAWINGS SHALL BE READ IN CONJUNCTION WITH THE ARCHITECTURAL AND OTHER CONSULTANTS' DRAWINGS, THE SPECIFICATION AND ALL OTHER WRITTEN INSTRUCTIONS THAT ARE ISSUED DURING THE COURSE OF THE WORKS.
- THE BUILDER SHALL CONFIRM ALL RELEVANT DIMENSIONS BEFORE COMMENCING CONSTRUCTION/FABRICATION.
- ALL DISCREPANCIES SHALL BE REFERRED TO THE ARCHITECT/ENGINEER FOR CLARIFICATION BEFORE PROCEEDING. NOTIFY THE ARCHITECT/ENGINEER OF ALL VARIATIONS ARISING FROM THE CLARIFICATION OF THE DISCREPANCY BEFORE PROCEEDING WITH THE WORKS.
- REFER TO ARCHITECTURAL DRAWINGS FOR DIMENSIONS NOT NOTED ON THE ENGINEERING DRAWINGS.
- DO NOT SCALE DRAWINGS.
- ALL DIMENSIONS ARE IN MILLIMETRES OR METRES UNLESS NOTED OTHERWISE (U.N.O.).
- NO SUBSTITUTIONS SHALL BE MADE WITHOUT THE WRITTEN APPROVAL OF THE ENGINEER.
- THE BUILDER SHALL MAINTAIN THE WORKS IN A SAFE, STABLE CONDITION AND ENSURE THAT NO PART IS OVER-STRESSED DURING CONSTRUCTION.
- ALL PROPS AND FORMWORK TO A BEAM OR SLAB SHALL BE REMOVED BEFORE ANY MASONRY IS CONSTRUCTED ON THAT BEAM OR SLAB.
- ALL NON LOAD BEARING WALLS SHALL BE CONSTRUCTED 20mm CLEAR OF SLAB AND BEAM SOFFITS U.N.O.
- THE ENGINEER ACCEPTS NO RESPONSIBILITY FOR THE WORKS UNLESS THE WORKS ARE INSPECTED AND APPROVED BY THE ENGINEER DURING CONSTRUCTION.
- A MINIMUM OF 48 HOURS NOTICE IS REQUIRED FOR ALL ENGINEERING INSPECTIONS U.N.O.
- THE STRUCTURAL WORKS HAVE BEEN DESIGNED FOR THE FOLLOWING LIVE LOADS:
AREA LIVE LOAD (kPa)

GROUND FLOOR
SUSPENDED FLOOR
SUSPENDED FLOOR PARTITION LOAD
HEAVY LOAD AREAS
STAIRS AND BALCONIES
ROOF

DESIGN CRITERIA - WIND:
REGION
TERRAIN CATEGORY
TOPOGRAPHIC MULTIPLIER (MT)
SHIELDING MULTIPLIER (MS)
STRUCTURAL IMPORTANCE MULTIPLIER (MI)

DESIGN CRITERIA - SEISMIC:
STRUCTURE TYPE
IMPORTANCE FACTOR
ACCELERATION COEFFICIENT
SITE FACTOR
EARTHQUAKE DESIGN CATEGORY

DESIGN CRITERIA - SNOW:

F - FOUNDATIONS AND FOOTINGS

- WORK AND MATERIALS MUST COMPLY WITH AS2870 & AS 3798.
- ALL EXCAVATIONS SHALL BE INSPECTED ON SITE AND THE ENGINEER NOTIFIED IMMEDIATELY IF CONDITIONS OTHER THAN THOSE DESCRIBED IN THE SOIL REPORT ARE ENCOUNTERED.
- FOOTINGS SHALL BE FOUNDED IN MATERIALS AND AT THE DEPTHS SHOWN ON THE DRAWINGS OR, WHEN NOT ON THE DRAWINGS, AS SHOWN IN THE SITE GEOTECHNICAL REPORT NO DATED, PREPARED BY
- THE SITE HAS BEEN CLASSIFIED AS CLASS IN ACCORDANCE WITH AS 2870.
- STRIP FOOTINGS ARE TO BE FOUNDED IN ORIGINAL UNDISTURBED GROUND WITH AN ALLOWABLE BEARING PRESSURE OF 150 kPa.
- PAD FOOTINGS ARE TO BE FOUNDED IN ORIGINAL UNDISTURBED GROUND WITH AN ALLOWABLE BEARING PRESSURE OF 150 kPa.
- FOUNDATION MATERIAL SHALL BE INSPECTED AND APPROVED BEFORE LYING MEMBRANES, FIXING REINFORCEMENT OR ORDERING CONCRETE.

SG - SLABS ON GROUND

- SLABS-ON-GROUND SHALL BE IN ACCORDANCE WITH AS2870.
- THE SITE OF THE WORKS SHALL BE STRIPPED OF ALL GRASS, ROOTS, VEGETABLE MATTER AND COMPRESSIBLE TOPSOIL.
- THE GROUND BELOW SLABS SHALL BE PROOF ROLLED WITH AN APPROVED HEAVY COMPACTOR. ALL "SOFT SPOTS" ENCOUNTERED SHALL BE REMOVED AND REPLACED WITH COMPACTED CRUSHED ROCK OR APPROVED FILL IN ACCORDANCE WITH AS2870 & AS3798.
- CLEAN GRANULAR FILLING UP TO 600mm MAY BE PLACED UNDER THE SLAB IN ACCORDANCE WITH THE PROVISIONS OF AS 2870 PART 6.4. FILLING SHALL BE COMPACTED IN 150mm THICK LAYERS BY MECHANICAL ROLLER OR EXCAVATOR.
- TERMITE PROTECTION SHALL BE PROVIDED AS REQUIRED BY AUSTRALIAN STANDARD AND THE LOCAL STATUTORY AUTHORITY.
- SLABS SHALL BE LAID ON A 0.2mm POLYTHENE MEMBRANE, CONTINUOUS, LAPPED 200mm MINIMUM AND TAPED AT PUNCTURES AND SERVICE AND PIPE PENETRATIONS. MEMBRANE TO EXTEND UNDER AND TO THE SIDES OF ALL SLABS, BEAMS AND THICKENINGS.
- BEAM AND STRIP FOOTING REINFORCEMENT SHALL HAVE A NOMINAL COVER OF 50mm.
- TRENCH MESH SHALL BE LAID CONTINUOUSLY AND SHALL BE SPLICED WHERE NECESSARY WITH A LAP OF 500mm.
- TRENCH MESH SHALL BE OVERLAPPED BY THE WIDTH OF FABRIC AT CORNERS AND INTERSECTIONS AND THE ENDS OF TRENCH MESH SHALL TERMINATE WITH A CROSSBAR.
- FABRIC SHALL BE PLACED NEAR THE TOP OF THE SLAB AND SHALL HAVE A NOMINAL COVER OF 25mm. UNO. FABRIC SHALL BE LAPPED A MINIMUM OF TWO WIRES PLUS 25mm AND SHALL BE SET OUT SUCH THAT NO MORE THAN THREE THICKNESSES OF FABRIC OCCUR AT ANY LOCATION.
- HOT WATER HEATING PIPES MAY BE EMBEDDED IN THE SLAB IF THE THICKNESS IS INCREASED BY 25mm AND LAID ON SL52 MESH.
- THE GROUND SURROUNDING THE SLAB SHALL HAVE ITS SURFACE AT LEAST 150mm LOWER THAN THE SLAB SURFACE AND BE GRADED AWAY FROM THE SLAB EDGE TO THE SITE DRAINAGE SYSTEM.
- OWNERS SHALL MAINTAIN THE SLAB AS NOTED IN APPENDIX B OF AS2870 AND IN THE CSIRO PUBLICATION "GUIDE TO HOMEOWNERS ON FOUNDATION MAINTENANCE AND FOOTING PERFORMANCE." IT IS THE BUILDERS RESPONSIBILITY TO ENSURE THAT THE OWNER IS INFORMED OF THESE REQUIREMENTS.

C - CONCRETE

- ALL WORK AND MATERIALS SHALL BE IN ACCORDANCE WITH AS3600.
 - CONCRETE SHALL HAVE A CHARACTERISTIC COMPRESSIVE STRENGTH AS FOLLOWS UNO: $f'_{c} = 32$ MPa
 - FOOTINGS $f'_{c} = 25$ MPa
SLAB-ON-GROUND $f'_{c} = \dots$ MPa
CONCRETE PANELS $f'_{c} = \dots$ MPa
SUSPENDED SLABS & BEAMS $f'_{c} = \dots$ MPa
MASS CONCRETE (BLINDING) $f'_{c} = \dots$ MPa
 - CONCRETE SHALL BE CURED BY AN APPROVED METHOD FOR AT LEAST 7 DAYS AFTER PLACEMENT.
 - CONCRETE SHALL BE COMPACTED USING MECHANICAL VIBRATION.
 - VIBRATION OF FORMS IS NOT ACCEPTABLE AND CONCRETE SHALL NOT BE SPREAD BY VIBRATING.
 - CONCRETE SECTIONS SHOWN ARE MINIMUM SIZES AND DO NOT INCLUDE FINISHES. SIZES SHALL NOT BE REDUCED IN ANY WAY OR HOLES FORMED OR MADE IN ANY MEMBER WITHOUT THE APPROVAL OF THE ENGINEER.
 - DEPTH OF BEAMS ARE GIVEN FIRST AND INCLUDE SLAB THICKNESS.
 - SLABS AND BEAMS ARE TO BE POURED TOGETHER UNO.
 - MINIMUM COVER (mm) TO ALL REINFORCEMENT INCLUDING FITMENTS SHALL BE AS FOLLOWS, UNO:
 - ELEMENT SURFACES IN CONTACT WITH GROUND SURFACES IN INTERIOR ENVIRONMENT ABOVE GROUND EXTERIOR ENVIRONMENT
- | ELEMENT | SURFACES IN CONTACT WITH GROUND | SURFACES IN INTERIOR ENVIRONMENT | ABOVE GROUND EXTERIOR ENVIRONMENT |
|------------------------------|---------------------------------|----------------------------------|-----------------------------------|
| INSITU COLUMN & PEDESTALS | 45 | 30 | 40 |
| INSITU BEAMS | 45 | 20 | 40 |
| FOOTINGS | 75 | - | - |
| PIERS | 70 | - | - |
| SLABS ON GROUND | 30 | 25 | 30 |
| SUSPENDED SLAB | 45 | 20 | 40 |
| INSITU WALLS | 45 | 25 | 30 |
| PRECAST | 40 | 30 | 30 |
| UNDERPINNING | 40 | 40 | 10 |
| x (REFER TO PRECAST DETAILS) | | | |
- REINFORCEMENT IS SHOWN DIAGRAMMATICALLY AND NOT IN TRUE PROJECTION.
 - SYMBOLS ON THE DRAWING FOR REINFORCEMENT ARE AS FOLLOWS:

- R DENOTES STRUCTURAL GRADE ROUND BARS
N DENOTES DEFORMED TENCORE BAR
SL DENOTES HARD DRAWN STEEL WIRE SQUARE FABRIC
RL DENOTES HARD DRAWN STEEL WIRE RECTANGULAR FABRIC
L DENOTES HARD DRAWN STEEL WIRE TRENCH MESH
 - ALL REINFORCEMENT AND INSERTS SHALL BE SUPPORTED AND HELD IN THE DESIGN LOCATION BY APPROVED CHAIRS, SPACERS OR TIES. BAR CHAIRS SHALL BE PLACED AT MINIMUM 1000 CENTRES IN TWO DIRECTIONS, UNO.
 - WELDING AND THREADING OF REINFORCEMENT IS NOT PERMITTED WITHOUT THE APPROVAL OF THE ENGINEER.
 - REINFORCEMENT SHALL BE EVENLY DISTRIBUTED OVER THE WIDTHS SHOWN UNO.
 - PROVIDE 2 -N12 x 1200 DIAGONALLY ACROSS RE-ENTRANT CORNERS OF SLABS, TIED UNDER TOP FABRIC.
 - AT SLAB EDGES INCLUDING CONSTRUCTION AND OTHER JOINTS AT LEAST ONE REINFORCING BAR OR FABRIC WIRE SHALL BE LOCATED PARALLEL TO AND WITHIN 75mm OF THE SLAB EDGE.
 - CONSTRUCTION JOINTS SHALL BE PROPERLY FORMED AND USED ONLY WHERE APPROVED OR PERMITTED BY THE ENGINEER.
 - SAWN JOINTS SHALL BE MADE AT A TIME APPROPRIATE TO THE CONCRETE MIX AND CLIMATIC CONDITIONS - GENERALLY WITHIN 10 AND 20 HOURS OF PLACING THE CONCRETE.
 - STRIPPING OF FORMS AND REMOVAL OF FORMWORK SHALL TAKE PLACE IN ACCORDANCE WITH A PROCEDURE AGREED WITH THE ENGINEER.
 - CONCRETE MUST BE SEPARATED FROM SUPPORTING BRICK WORK BY TWO LAYERS OF A SUITABLE DE-BONDING MEMBRANE.
 - SUSPENDED SLABS SHALL BE GIVEN AN UPWARD MID SPAN CAMBER OF 3mm PER 1000mm. BEAMS SHALL BE CAMBERED AS SHOWN ON DRAWINGS.
 - SPLICES IN REINFORCEMENT SHALL BE MADE IN THE POSITIONS SHOWN ON THE DRAWINGS OR AS OTHERWISE APPROVED BY THE ENGINEER.
 - HOLDING DOWN BOLTS SHALL BE SUPPLIED TO THE CONCRETOR FOR CASTING INTO THE CONCRETE AND SHALL BE INSTALLED IN ACCORDANCE WITH THE STEEL HOLDING DOWN BOLT PLAN.
- S - STRUCTURAL STEELWORK**
- ALL WORK AND MATERIALS SHALL BE IN ACCORDANCE WITH AS4100.
 - FABRICATION AND ERECTION SHALL BE IN ACCORDANCE WITH AS 4100 AND SAA/SNZ HB62
 - HOT ROLLED AND WELDED PRODUCTS SHALL BE BHP 300PLUS AND PLATE SHALL BE GRADE 250 MATERIAL (UNO).
 - ALL WELDS SHALL BE CONTINUOUS FILLET WELD, SIZE 6mm, GP CATEGORY USING E41XX/W40X CONSUMABLES U.N.O.
 - ALL WELDING SHALL BE IN ACCORDANCE WITH AS1554.
 - BOLTS SHALL BE M20 8.8/5 UNO.
 - HOLDING DOWN BOLTS SHALL BE M20 4.6/5, GALVANISED U.N.O.
 - CONNECTIONS NOT SPECIFICALLY DETAILED SHALL BE IN ACCORDANCE WITH THE APPROPRIATE CONNECTION DETAILED IN THE AISC STANDARDISED STRUCTURAL CONNECTIONS MANUAL.
 - ALL CLEAT PLATES AND STIFFENERS SHALL BE 10mm THICK U.N.O.
 - THE ENDS OF ALL TUBULAR MEMBERS SHALL BE SEALED WITH A 3mm PLATE U.N.O.
 - TUBULAR MEMBERS TO BE GALVANISED SHALL BE ADEQUATELY VENTED.
 - PURLINS AND GIRTS SHALL BE IN ACCORDANCE WITH AS/NZS 4660, GALVANISED AND INSTALLED IN ACCORDANCE WITH THE MANUFACTURER'S RECOMMENDATIONS.
 - BEFORE COMMENCING FABRICATION 3 COPIES OF THE SHOP DRAWINGS SHALL BE SUBMITTED TO THE ENGINEER FOR REVIEW. THIS REVIEW DOES NOT REMOVE THE RESPONSIBILITY FOR THE INTERPRETATION OF THE DRAWINGS, DIMENSIONAL ACCURACY AND THE STEEL FABRICATION FROM THE STEEL FABRICATOR/BUILDER.
 - CAMBER SHALL BE AS NOTED ON THE DRAWINGS, OR IF NOT NOTED 5mm FOR EVERY 2000mm.
 - STRUCTURAL STEEL TO BE CONCRETE ENCASED SHALL BE WRAPPED WITH F41 MESH. THE GAP BETWEEN THE STRUCTURAL STEEL AND THE MESH AND THE EXTERNAL COVER TO THE MESH SHALL BE 25mm AND 50mm RESPECTIVELY.
 - ALL BOLTS AND STRUCTURAL STEEL EXPOSED TO THE WEATHER SHALL BE HOT DIP GALVANISED U.N.O.
 - ALL STEEL LINTELS SUPPORTING MASONRY EXPOSED TO THE WEATHER SHALL BE HOT DIP GALVANISED.
 - PROVIDE ALL NECESSARY CLEATS AND HOLES REQUIRED TO FIX TIMBER AND OTHER MATERIALS AND FINISHES TO THE STEELWORK.
 - LINTELS SHALL NOT BE PROPPED DURING LOAD APPLICATION (UNO).
 - PROVIDE MINIMUM 150mm END BEARING AND LEVELLING GROUT FOR STEELWORK SEATED ON MASONRY U.N.O.
 - PROTECTIVE COATINGS
PREPARATION CLASS 2A ABRASIVE BLAST
 - FIRST COAT/ INORGANIC ZINC SILICATE 125 DRY FILM THICKNESS
SECOND COAT INORGANIC ZINC SILICATE 125 DRY FILM THICKNESS
THIRD COAT INORGANIC ZINC SILICATE 125 DRY FILM THICKNESS
 - COATINGS DAMAGED DURING TRANSPORT AND ERECTION SHALL BE MADE GOOD.

REVISION A: 12/06/2013 - ISSUED FOR APPROVAL

DRAWN: M.G.

DATE: JUNE 2013

SCALE: AS SHOWN

DRG. No: 14869/13

ALL DIMENSIONS AND CONDITIONS TO BE CHECKED PRIOR TO ORDERING OR PLACING ANY MATERIALS. DO NOT SCALE THIS DRAWING. WRITTEN MEASUREMENTS TAKE PRECEDENCE.



Len Price & Associates Pty. Ltd.
Consulting Engineers
10 Fryers Street, Shepparton. Telephone (03) 58 228008

DRAWING: NOTES

PROJECT: CITY OF GREATER SHEPPARTON GOULBURN VALLEY SIGNAGE STRATEGY

REVISION A

SHEET 2 OF 2

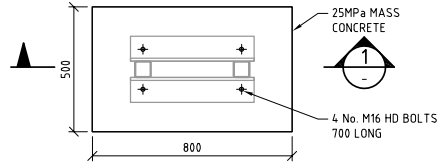

2100 x 500 PLINTH FOOTING PLAN
SCALE 1:20

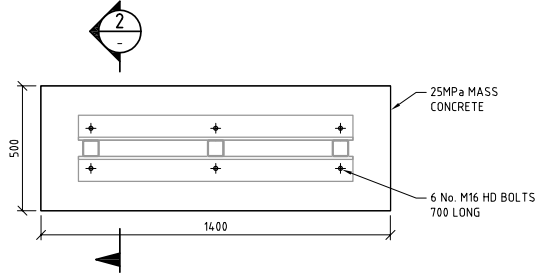

700 x 1100 PLINTH FOOTING PLAN
SCALE 1:20

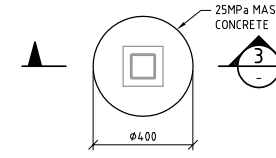

DIRECTIONAL FINGERBOARD FOOTING PLAN
SCALE 1:20

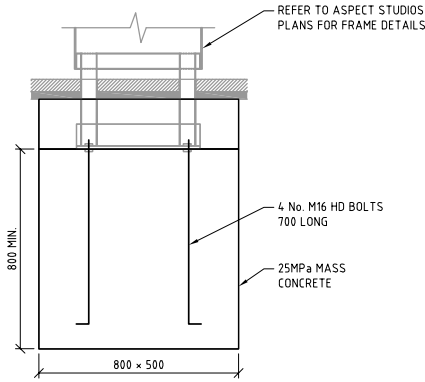

SECTION 1
SCALE 1:20

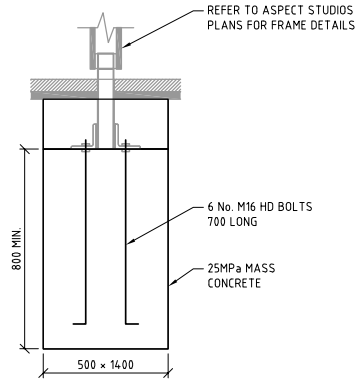

SECTION 2
SCALE 1:20

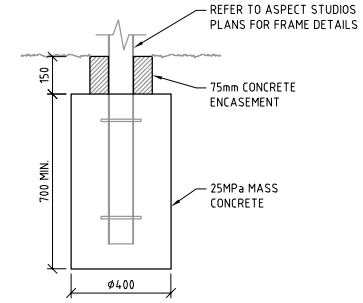

SECTION 3
SCALE 1:20

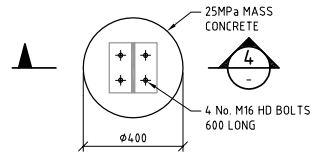

TRAIL MARKER FOOTING PLAN
SCALE 1:20

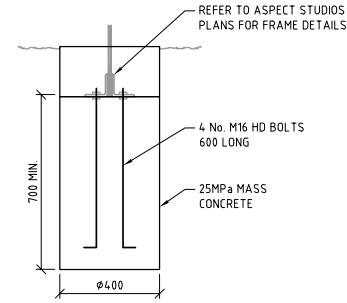

SECTION 4
SCALE 1:20

REVISION A: 12/06/2013 - ISSUED FOR APPROVAL

DRAWN: M.G.

DATE: JUNE 2013

SCALE: AS SHOWN

DRG. No: 14869/13

ALL DIMENSIONS AND CONDITIONS TO BE OBSERVED AND STRICTLY ADHERED TO PRIOR TO ORDERING OR PLACING ANY MATERIALS. DO NOT SCALE THIS DRAWING. WRITTEN MEASUREMENTS TAKE PRECEDENCE.

Len Price & Associates Pty. Ltd.
Consulting Engineers
10 Fryers Street, Shepparton. Telephone (03) 58 222808

DRAWING: FOOTING DETAILS

PROJECT: CITY OF GREATER SHEPPARTON, GOULBURN VALLEY SIGNAGE STRATEGY

REVISION A
SHEET 1 OF 2